

Uniden®

INSTRUCTION MANUAL

UDC-7M

Digital Camera

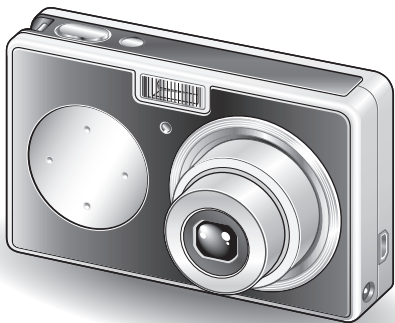

Congratulations on your purchase of the Uniden UDC-7M Digital Camera.

- Please be sure to read this Instruction Manual before you begin using your camera.
- Save this manual for future reference.
- Review the separate booklet "SAFETY MANUAL" before operating your camera.

Warning

TO PREVENT THE RISK OF FIRE OR ELECTRIC SHOCK, DO NOT EXPOSE THIS APPLIANCE TO RAIN OR MOISTURE

■ FOR AMERICAN USERS

The following advisory is included in accordance with the laws of the State of California (USA):

WARNING:

This product contains chemicals, including lead, known to the State of California to cause cancer, birth defects or other reproductive harm. **Wash hands after handling.**

- This equipment has been tested and found to comply with the limits for a Class B digital device, pursuant to Part 15 of the FCC Rules. These limits are designed to provide reasonable protection against harmful interference in a residential installation. This equipment generates, uses and can radiate radio frequency energy and, if not installed and used in accordance with the instructions, may cause harmful interference to radio communications. However, there is no guarantee that interference will not occur in a particular installation. If this equipment does cause harmful interference to radio or television reception, which can be determined by turning the equipment off and on, the user is encouraged to try to correct the interference by one or more of the following measures:
 - Reorient or relocate the receiving antenna.
 - Increase the separation between the equipment and receiver.
 - Connect the equipment into an outlet on a circuit different from that to which the receiver is connected.
 - Consult the dealer or an experienced radio/TV technician for help.
- Changes or modifications not expressly approved by the party responsible for compliance could void the user's authority to operate the equipment.

Declaration of Conformity

Model number: UDC-7M

Trade Name: Uniden Corporation

Address: 4700 Amon Carter Boulevard Ft. Worth TX, 76155 U.S.A

Telephone No.: 817-858-3300

This device complies with Part 15 of the FCC Rules. Operation is subject to the following two conditions:

- (1) this device may not cause harmful interference, and
- (2) this device must accept any interference received, including interference that may cause undesired operation.

■ FOR CANADIAN USERS

- This Class B digital apparatus complies with Canadian ICES-003.

GETTING UP AND RUNNING

Install the battery pack

1 Use the supplied charger to charge the battery pack.

- The CHARGE indicator lights red during charging.
- The CHARGE indicator will turn off when the battery pack is fully charged.
- Charging takes approximately 90 minutes.

To power outlet

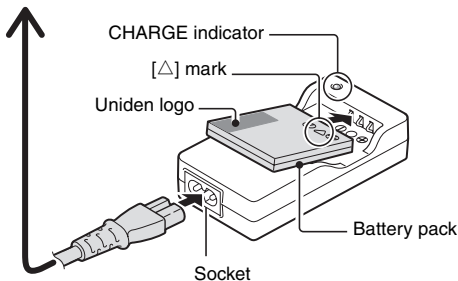

2 Open the battery/card compartment cover, and insert the battery pack.

- The battery/card compartment cover is located on the side of the camera.
- Press the on/off button to turn the camera on.

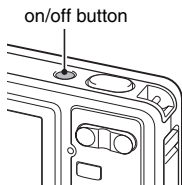
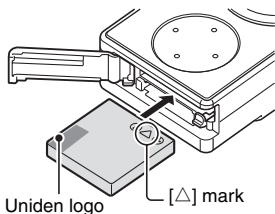

Shooting

- 1 Press the [▲] button.
 - The shooting mode menu appears.

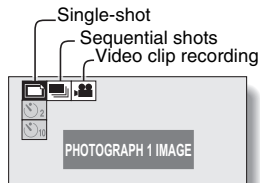

- 2 Press the [◀] or [▶] button to select the shooting mode.

- 3 Press the ok button.
 - The shooting mode is indicated by an icon in the upper left area of the monitor.

- 4 Press the shutter button.

Single-shot mode:
A still image is captured.

Sequential shots mode:
Shooting begins. Release the shutter button to discontinue shooting.

Video clip recording mode:
Recording begins. To stop recording, press the shutter button again.

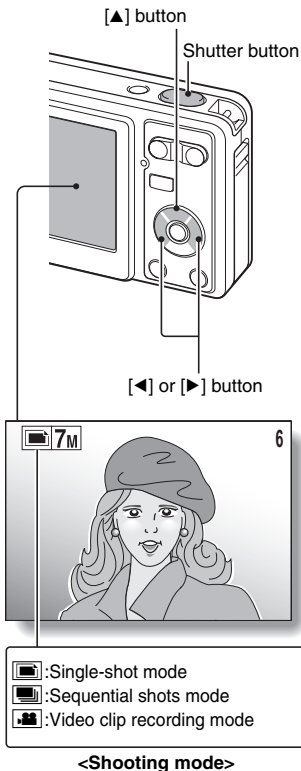

GETTING UP AND RUNNING

Playback

■ Still image playback

1 Press the playback button [▶].

- The display switches to the Playback Screen.
- To view other images, press the [◀] or [▶] button.
- If the playback button [▶] is pressed, the display returns to the Shooting Screen.

■ Video clip playback

1 Press the playback button [▶].

- The display switches to the Playback Screen.
- Press the [◀] or [▶] button to display the video clip you wish to play back.
- Video clips are indicated by a video clip pattern along the top and bottom of the screen.

2 Press the ok button.

- Playback of the selected video clip begins.
- If the playback button [▶] is pressed again, the display changes to the Shooting Screen.

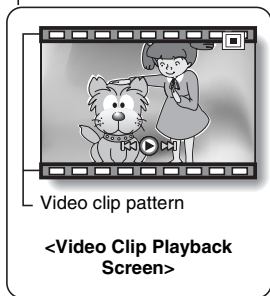
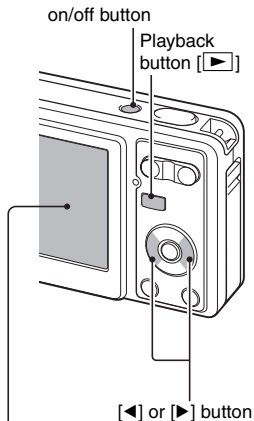

When you are finished taking pictures...

Press the on/off button to turn the camera off.

CONTENTS

CONTENTS	1
QUICK SEARCH BY OPERATION	3
CHECKING THE INCLUDED ACCESSORIES	7
GETTING THE MOST OUT OF YOUR CAMERA	9
SYSTEM MAP	10

■ SETUP

PARTS NAMES	11
CHARGING THE BATTERY PACK	13
INSTALL THE BATTERY PACK AND CARD	16
TURNING THE CAMERA ON AND OFF	18
DATE AND TIME SETTING	20

■ BASIC OPERATION

BEFORE TAKING PICTURES	23
CAPTURING AND PLAYING BACK STILL IMAGES	30
SHOOTING SEQUENTIAL SHOTS	37
VIDEO CLIP RECORDING AND PLAYBACK	38
USING THE SCENE FUNCTION	42
USING THE ZOOM	46
FLASH SETTING	47
SELF-TIMER	49
FOCUS RANGE	51

■ SHOOTING

ACCESSING THE RECORDING MENU	52
RESOLUTION/VIDEO SIZE SETTING	55
FOCUS AREA SETTING	58
ISO SENSITIVITY	60
WHITE BALANCE	61
EXPOSURE CORRECTION	62
DATE IMPRINT	63

■ **PLAYBACK**

DISPLAYING THE PLAYBACK MENU	64
IMAGE PROTECT	66
ROTATE IMAGE	67
CONTRAST CORRECTION	68
COPY DATA	70
PRINT SETTINGS	72
SLIDESHOW PLAYBACK	76
DISPLAYING STILL IMAGE PROPERTIES	77

■ **OPTION**

DISPLAYING THE OPTION MENU	78
SOUNDS	81
POST-VIEW SETTING	83
ADJUST THE MONITOR BRIGHTNESS	84
SCREEN LANGUAGE	85
TV SYSTEM SETTING	86
AUTO POWER OFF FUNCTION	87
FILE No. RESET FUNCTION	88
INITIALIZING THE CARD MEMORY AND INTERNAL MEMORY	91
RESETTING THE CAMERA SETTINGS	93
CHECKING THE REMAINING INTERNAL MEMORY AND CARD MEMORY	94
CHECKING THE REMAINING BATTERY CHARGE	96

■ **OTHER DEVICES AND CONNECTIONS**

CONNECTING TO A TV	98
CONNECTING TO A COMPUTER	99
DIRECT PRINTING	106

■ **APPENDICES**

COMMONLY ASKED QUESTIONS	114
TROUBLESHOOTING	120
SPECIFICATIONS	126

QUICK SEARCH BY OPERATION

Your camera has an abundance of convenient features and functions. From creating precisely the photo you want, to viewing images using various techniques, you can locate the exact operation for your purposes in the following table.

Shooting/recording		
Basic operation	Convenient functions	Additional functions
Getting started shooting <ul style="list-style-type: none">• "Recording a video clip" on page 38• "Shooting single shots" on page 30• "SHOOTING SEQUENTIAL SHOTS" on page 37	Log the date and time of your photos <ul style="list-style-type: none">• "DATE AND TIME SETTING" on page 20 Zoom in on the subject <ul style="list-style-type: none">• "USING THE ZOOM" on page 46 Close-up photography <ul style="list-style-type: none">• "FOCUS RANGE" (macro mode) on page 51	For more accurate focus <ul style="list-style-type: none">• "FOCUS RANGE" (manual focus) on page 51 Set the focus to a narrow range <ul style="list-style-type: none">• "FOCUS AREA SETTING" on page 58
Optimize the photo quality <ul style="list-style-type: none">• "RESOLUTION/VIDEO SIZE SETTING" on page 55		
Capture fast-moving subjects <ul style="list-style-type: none">• "USING THE SCENE FUNCTION" (sports mode) on page 42		

Shooting/recording		
Basic operation	Convenient functions	Additional functions
Shoot in dark conditions <ul style="list-style-type: none"> • “EXPOSURE CORRECTION” on page 62 • “FLASH SETTING” on page 47 • “USING THE SCENE FUNCTION” (night view portrait mode/fireworks mode/lamp mode) on page 42 		
	Increase the camera’s sensitivity <ul style="list-style-type: none"> • “ISO SENSITIVITY” on page 60 	
Photographing people <ul style="list-style-type: none"> • “USING THE SCENE FUNCTION” (portrait mode/night view portrait mode/face chaser mode) on page 42 • “FLASH SETTING” (red-eye reduction) on page 47 		
Photographing landscapes <ul style="list-style-type: none"> • “USING THE SCENE FUNCTION” (landscape mode) on page 42 		
Take a self-photo <ul style="list-style-type: none"> • “SELF-TIMER” on page 49 		
	Make images lighter or darker <ul style="list-style-type: none"> • “EXPOSURE CORRECTION” on page 62 	Adjust the camera’s sensitivity <ul style="list-style-type: none"> • “ISO SENSITIVITY” on page 60
	Change the color of the images <ul style="list-style-type: none"> • “USING THE SCENE FUNCTION” (monochrome/sepia) on page 42 	Make white appear natural <ul style="list-style-type: none"> • “WHITE BALANCE” on page 61

QUICK SEARCH BY OPERATION

Playback		
Basic operation	Convenient functions	Additional functions
Getting started viewing images <ul style="list-style-type: none">• "Playing back the video clip" on page 39	Adjust the playback volume <ul style="list-style-type: none">• "SOUNDS" on page 81	
<ul style="list-style-type: none">• "Viewing still images" on page 32	Search for image data <ul style="list-style-type: none">• "9-image display playback" on page 33 Magnify an image <ul style="list-style-type: none">• "Magnifying (zooming in) the image" on page 34	Change the angle of view <ul style="list-style-type: none">• "ROTATE IMAGE" on page 67
Slideshow playback <ul style="list-style-type: none">• "SLIDESHOW PLAYBACK" on page 76		
Adjust the monitor brightness <ul style="list-style-type: none">• "ADJUST THE MONITOR BRIGHTNESS" on page 84		
Playback on a TV <ul style="list-style-type: none">• "CONNECTING TO A TV" (for playback) on page 98		Set the TV system <ul style="list-style-type: none">• "TV SYSTEM SETTING" on page 86

Data managing/processing		
Basic operation	Convenient functions	Additional functions
Edit photos <ul style="list-style-type: none"> • "CONTRAST CORRECTION" on page 68 		
Copy files from the internal memory to the card, or vice versa <ul style="list-style-type: none"> • "COPY DATA" on page 70 		
Delete files <ul style="list-style-type: none"> • "Erasing files" on page 35 	Protect images from accidental erasure <ul style="list-style-type: none"> • "IMAGE PROTECT" on page 66 Format a card <ul style="list-style-type: none"> • "INITIALIZING THE CARD MEMORY AND INTERNAL MEMORY" on page 91 	
Specify the number of prints and date imprint <ul style="list-style-type: none"> • "PRINT SETTINGS" on page 72 		
View the settings that were in effect when the image/audio data was recorded <ul style="list-style-type: none"> • "DISPLAYING STILL IMAGE PROPERTIES" on page 77 		

CHECKING THE INCLUDED ACCESSORIES

- Lithium-ion battery pack (battery pack): 1

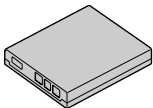

- Lithium-ion battery pack charger and power cord

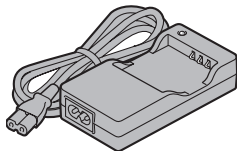

- Dedicated USB interface cable: 1

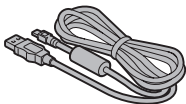

- Dedicated video interface cable: 1

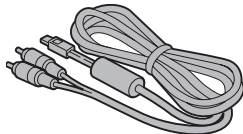

- “SAFETY MANUAL” (safety precautions booklet)
Please read this booklet carefully before using the digital camera.



- Wrist Strap: 1

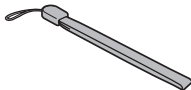

Attaching the handstrap

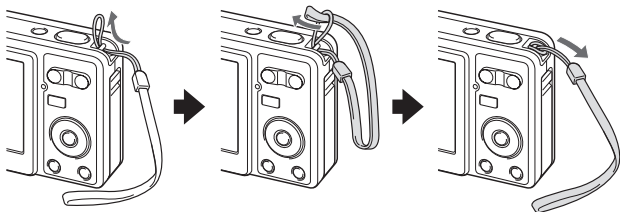

Media cards that can be used with this camera

The types of card that can be inserted into and used with this camera are:

- SD Memory Card
- Multi Media Card

What “card” means in this manual

- In this manual, SD Memory Cards and Multi Media Cards that can be used in this digital camera are referred to as “card”.
- The cards in the illustrations in this manual are SD Memory Cards, but all installation and removal procedures are the same for both SD Memory Cards and Multi Media Cards.

GETTING THE MOST OUT OF YOUR CAMERA

Your UDC-7M is loaded with lots of functions including an easy-to-understand display, a large screen, extensive scene functions, and more.

■ Abundant scene functions

You can select from a variety of preset settings (aperture, shutter speed, etc.) for specific shooting conditions.

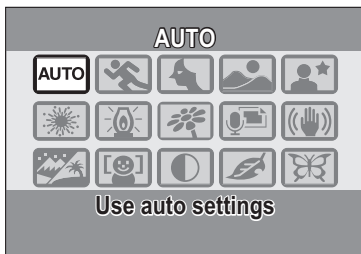

■ Speedy mode-switching

Switch the shooting mode from still images to video clips to sequential shots with a single button operation.



SYSTEM MAP

The included accessories can be used to connect your camera to a computer, printer or TV. By connecting the camera to your computer, you can, for example, copy your photos to the computer's hard disk. You can connect it to a printer for direct printing of your photos. Or take the card to a photo shop to have your photos printed there.

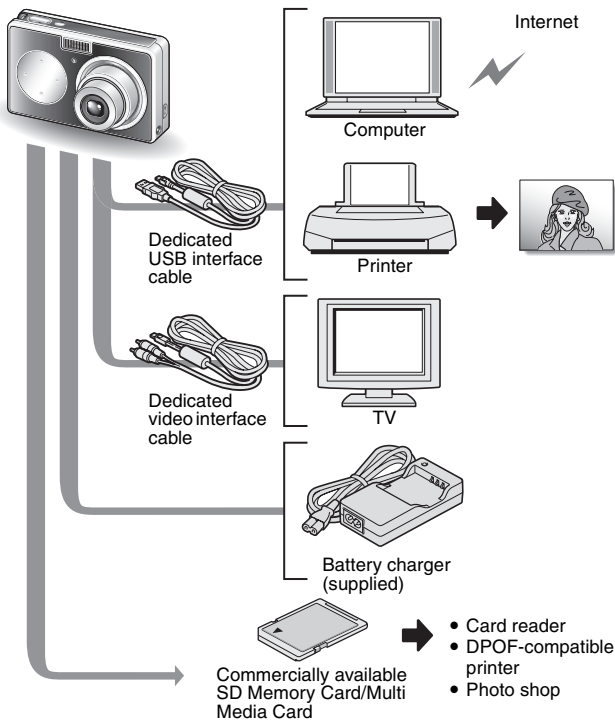

PARTS NAMES

Front

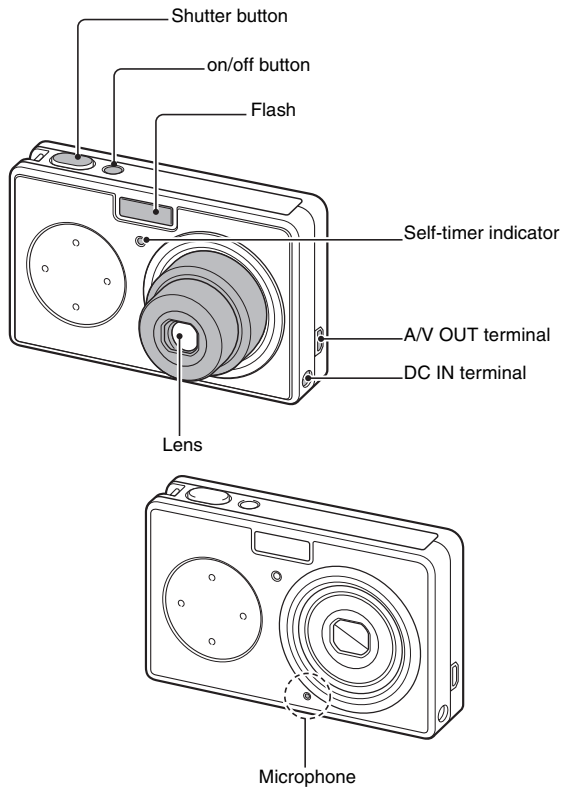

Rear

Illumination sensor

- Detects the ambient brightness and automatically adjusts the brightness of the monitor accordingly.

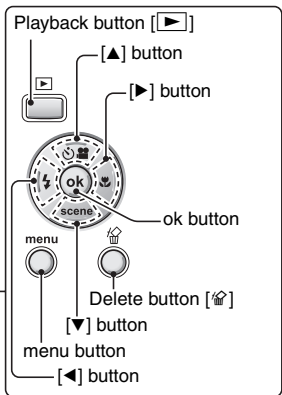
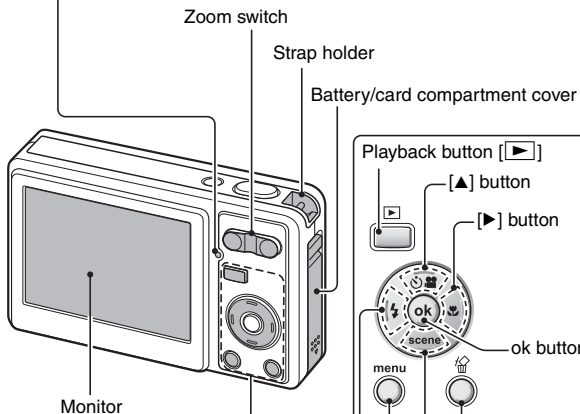

Bottom

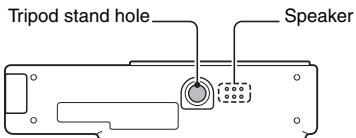

CHARGING THE BATTERY PACK

Please charge the supplied battery pack before using it.

1 Insert the battery pack in the battery charger.

- Insert it in the direction indicated by the [△] mark on the battery pack, with the Uniden logo facing up.

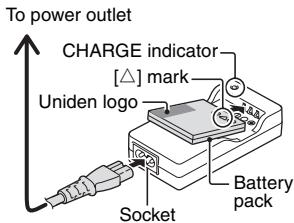

2 Connect the supplied power cord to the socket on the battery pack charger.

- Insert the connector straight and securely.

3 Plug the power plug into a power outlet.

- Recharging begins.
- During recharge, the CHARGE indicator is lit red.

4 When the CHARGE indicator turns off, unplug the power cord from the power outlet, and remove the battery pack from the charger.

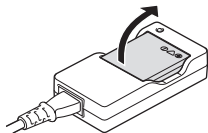

HINT

- The recharge time is approx. 90 minutes.

RECHARGING THE BATTERY PACK

Be sure to fully charge the supplied battery pack before using it in your camera. For charging the battery pack, use the supplied charger.

Charge the battery pack if it is being used for the first time, and recharge it whenever the remaining charge is low (see “CHECKING THE REMAINING BATTERY CHARGE” on page 96).

- During recharging, the charger and battery pack will be warm. This is normal and does not indicate a malfunction.

If there is interference to your TV or radio during recharging...

- Move the battery pack and charger further away from the TV or radio.

Ambient temperature during recharging

- It is recommended that the ambient temperature during recharging be between about 10°C and 35°C (50°F and 95°F). Due to the characteristics of the battery pack, at temperatures below 0°C (32°F), it may not be possible to sufficiently recharge it.
- When the battery pack temperature is high, it may take longer to recharge it.

Recharge a battery pack in the following cases

- A battery pack which has not been used for a long time
- Newly purchased battery pack

CHARGING THE BATTERY PACK

About the CHARGE indicator

The CHARGE indicator shows the status of the battery pack and the charger.

Please refer to the following table if the indicator flashes abnormally.

CHARGE indicator

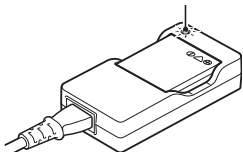

CHARGE indicator	
Not lit	Not connected properly <ul style="list-style-type: none">To recharge the battery pack, the power cord of the charger must be connected to a power outlet, and the plug at the other end inserted in the charger's power socket (page 13).The battery pack is not installed, or it is not installed correctly (page 13). Recharging finished
Lit red	Recharging
Red flashing	Problem with the battery pack or battery pack charger <ul style="list-style-type: none">Immediately remove the battery pack from the charger.Do not use an abnormal battery pack. (The usable life of the battery pack has probably expired.)

About the internal backup battery

- This camera's internal battery serves to maintain the date and time settings, as well as the shooting settings. The backup battery will be fully charged when the battery pack is kept in the camera continuously for about 2 days. In the fully charged state, the backup battery will maintain the camera settings for about 7 days.

When not using the camera for a long time, remove the battery pack

- A small amount of power is still used even if the digital camera is turned off, and it is therefore recommended that the battery pack be removed from the camera if it is not going to be used for a long time. Note that when the battery pack is removed for a long period, the time and date settings may be cleared. Before using your camera again, be sure to confirm that the camera settings are correct.

INSTALL THE BATTERY PACK AND CARD

1 Insert the battery pack and card.

- The card can be used after it has been formatted with the camera (page 91).
- Make sure that the battery pack and card orientation are correct.
- When inserting the battery pack, be careful of the latch that secures it.

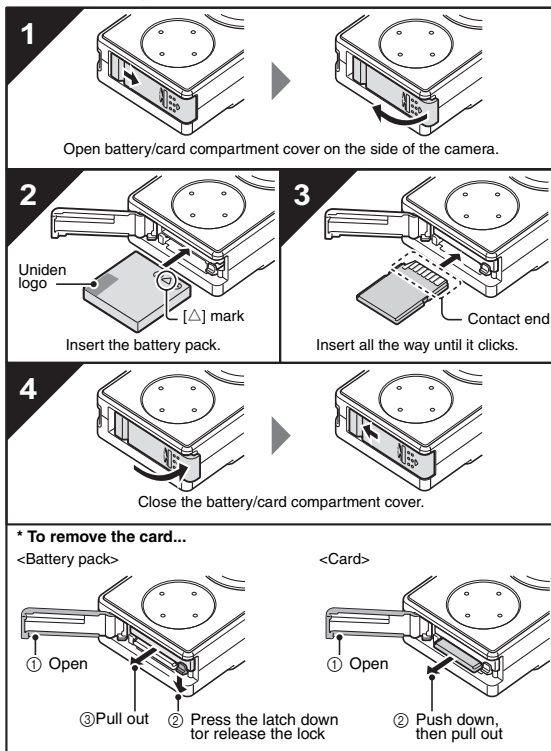

INSTALL THE BATTERY PACK AND CARD

CAUTION

Be careful when removing the card.

- Do not attempt to forcibly remove the card.
- Never remove the card when the camera is connected to a computer or printer, or when the self-timer indicator is flashing quickly. In doing so, you risk losing the data stored in the card.

Keep your finger on the card until it is completely inserted or released.

- If you remove your finger too soon, the card may spring out and become lost or hit someone in the eye.

HINT

Shooting without a card installed

- When a card is installed, images are recorded to and played back from the card. When no card is installed, images are recorded to and played back from the camera's internal memory. When the camera is turned on with no card installed, the internal memory icon  is shown on the monitor to let you know that the images you capture will be saved to the camera's internal memory.

TURNING THE CAMERA ON AND OFF

Turning on the camera

In the shooting mode

- 1 **Press the on/off button.**
 - The camera turns on.
 - The camera turns on in the shooting mode that was active before it was last turned off.

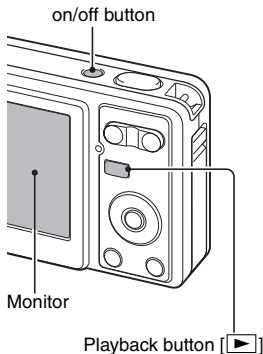

In the playback mode

- 1 **Press the playback button [▶] for at least one second.**
 - The Playback Screen appears on the monitor (pages 32 and 39).

Turning off the camera

- 1 **Press the on/off button.**
 - The camera turns off.
 - <If the camera was turned on by pressing the playback button [▶]>**
 - When the playback button [▶] or on/off button is pressed, the camera turns off.

TURNING THE CAMERA ON AND OFF

About the auto power off function

In order to preserve battery pack power when, for example, the camera has accidentally been left on, the camera is furnished with an “auto power off” function by which the camera automatically turns off after a certain period of inactivity (about 1 minute during shooting or about 3 minutes during playback [factory default settings]).

- If the auto power save function has operated to turn the camera off, press the on/off button or the playback button [▶] to turn it back on.
- You can change the setting for the time elapsed before the camera automatically turns off (page 87).
- When the camera is connected to a computer or printer using the dedicated USB interface cable, the auto power save function is disabled, and the camera turns off after about 12 hours.

HINT

If the  icon appears...

- When a picture is taken, the date and time it was captured is recorded with it. When the date and time cannot be recorded with the image because the date and time have not yet been set (page 20), the  icon appears. To have the date and time recorded with images, please make this setting before capturing images.

DATE AND TIME SETTING

The camera will record the date and time an image is captured so that you can display them during playback. Therefore, before capturing images, make sure the correct date and time are set.

Example: To set the clock to 7:30 p.m. on December 24, 2006

- 1 Press the on/off button to turn the camera on, and press the menu button.**

- The Recording Menu appears (page 52).

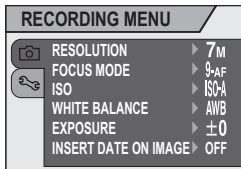

- 2 Press the [▼] button to select the  tab, and press the [▶] button.**

- The Option Menu appears.

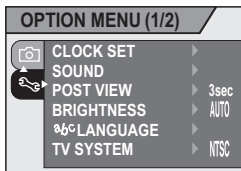

- 3 Press the [▲] or [▼] button to select "CLOCK SET", and press the ok button or the [▶] button.**

- The Clock Set Screen appears.
- The current date and time settings are shown.
- Follow the procedures below to enable or disable the date display during playback, to set the display format for the date, and to set the date and time.
- To return to the Option Menu, press the menu button.

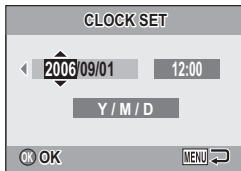

DATE AND TIME SETTING

4 Set the date and time.

- ① Press the [▲] or [▼] button to change the year indication.
 - Repeat these steps to select the month indication and day indication, and set the date to December 24, 2006.
- ② Press the [▶] button to select the time indication.
- ③ Press the [▲] or [▼] button to change the time setting.
- ④ Press the [▶] button to select the Y/M/D indication.
- ⑤ Press the [▲] or [▼] button to change the displayed date order.

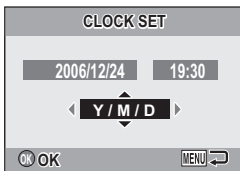
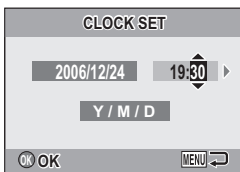
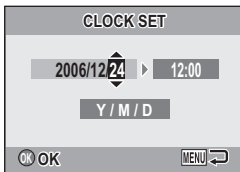

- Press the [▼] button to change the displayed date order as follows:

→ Y / M / D → M / D / Y → D / M / Y → DISP OFF →

- Press the [▲] button to change it in the reverse order.

5 Press the ok button.

- The date and time setting is completed, and you are returned to the Option Menu.
- The Option Menu is canceled when the menu button is pressed.

HINT

- Under normal conditions, while the battery pack is being replaced, an internal battery will maintain the date and time settings. However, there is a small chance the settings may be lost. (The backup will last for about 7 days.) It is recommended to check that the date and time settings are still correct after replacing the battery pack and before shooting or recording of any type (follow steps **1** to **3**).

To correct the date and time settings

- In step **4**, select the indication that you want to change, and follow the procedure to change the indication.

BEFORE TAKING PICTURES

How to hold the camera

Hold the camera securely, keeping your elbows close to your body and making sure the camera is stable.

Correct hold



Incorrect hold



A finger is blocking the lens or flash.

Make sure that the lens and flash are not blocked by your fingers or the handstrap.

HINT

- Images captured in the still image shooting mode can be rotated when they are played back (page 67).
- When the optical zoom is used or when the autofocus is operating, the image may appear to waver, but this is not a malfunction.

Using the autofocus

The autofocus will work in almost all situations; however, there are certain conditions that may cause the autofocus function to not work properly. If the autofocus function is not working properly, set the focus range to capture images (page 51).

■ Conditions that may cause incorrect focus

The following examples are some of the situations where the autofocus function may not work.

- **Subjects with low contrast, very bright subjects at the center of the image or dark subjects or locations**

Use the focus-lock function to lock the focus on an object with contrast at the same distance as the desired subject.



- **Subjects without vertical lines**

Use the focus-lock function to lock the focus while framing the subject vertically, then re-orient the camera to compose a horizontally framed image.

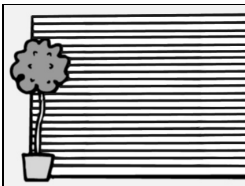

BEFORE TAKING PICTURES

The following examples are some of the situations where the autofocus function may work, but not as desired.

- **When both near and far objects are present**

Use the focus-lock function to lock the focus on an object at the same distance as the desired subject, then reposition the camera to compose the picture.



- **Fast-moving subjects**

Use the focus-lock function to lock the focus on an object at the same distance as the desired subject, then reposition the camera to compose the picture.

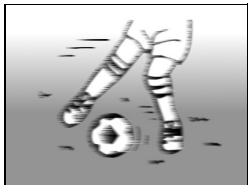

Switching between the shooting mode and playback mode

- 1 Press the on/off button to turn the camera on.

- 2 Press the playback button [▶].
 - Each time the playback button is pressed, the camera switches between the shooting mode and the playback mode.

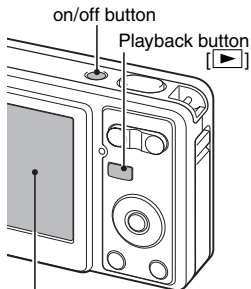

<Shooting mode>

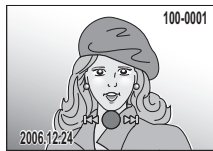

<Playback mode>

HINT

To turn the camera on in the playback mode

- Press the playback button [▶] for at least 1 second, and the camera will turn on in the playback mode.

BEFORE TAKING PICTURES

How to switch the shooting mode

Your camera can capture single still photos (single-shot mode), record video clips (video clip recording mode), and also capture a series of still photos (sequential shots mode).

1 Press the on/off button to turn the camera on.

2 Press the [▲] button.

- The screen to set the shooting mode and the self-timer appears.



3 Press the [▶] button to select the shooting mode.

4 Press the ok button.

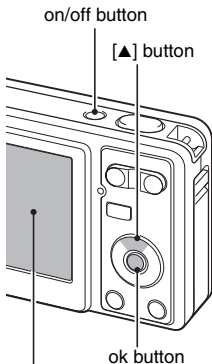
- The selected shooting mode is set.
- An icon in the upper left area of the monitor indicates the active shooting mode setting.



<Shooting mode>

- : Single-shot mode
- : Sequential shots mode
- : Video clip recording mode

Switching the display mode

In the shooting mode, you can select either the “settings display mode” which allows you to confirm the shooting settings on the monitor while you shoot, or the “normal display mode” in which the setting indications are turned off, providing a full view of the subject.

- 1 Press the on/off button to turn the camera on.**

- 2 Press the ok button.**

- Each time the ok button is pressed, the camera switches between the settings display mode and the normal display mode.

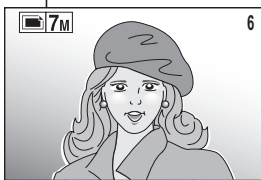
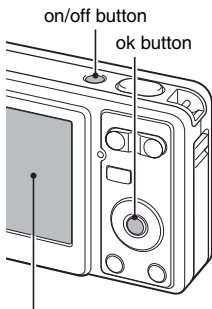

<Settings display mode>



<Normal display mode>

BEFORE TAKING PICTURES

Hints for taking pictures

Muting the camera sounds

- The operation sounds that are generated, for example, when the shutter button, menu button or ok button is pressed, can be muted (page 81).

Where is the image data saved?

- All the image and sound data is recorded in the camera's internal memory or on the card installed in the camera.
- When a card is installed in the camera, the data is recorded on the card. If no card is installed, the data is recorded in the camera's internal memory.

Taking pictures in backlight conditions...

- When taking pictures with the light coming from behind the subject, due to the characteristics of the CCD, light lines or ghost patterns (flare phenomenon) may appear in the captured image. In this situation, it is recommended that you avoid taking pictures with the subject lit from behind.

CAPTURING AND PLAYING BACK STILL IMAGES

There are two modes for capturing still images. In the normal still image mode, one image is captured each time the shutter button is pressed. In the sequential shots mode, when you press the shutter button, several successive images are captured. For more information about taking sequential shots, please see page 37.

Shooting single shots

- 1 Set the camera to the single-shot mode (page 27).**

- 2 Press the shutter button halfway.**
 - Engage the autofocus by pressing the shutter button halfway (focus lock).

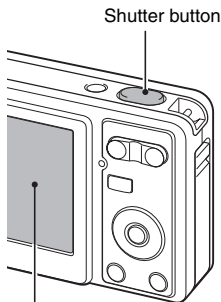

- 3 Continue to gently press the shutter button all the way.**
 - Press the shutter button gently, taking care not to move the camera.
 - The image that was captured appears on the monitor as long as the shutter button is kept pressed (post view).

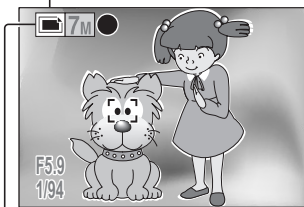
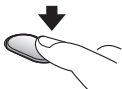

Single-shot icon

<Single-Shot Screen>

CAPTURING AND PLAYING BACK STILL IMAGES

4 Release your finger from the shutter button.

- The captured image is recorded.

HINT

What is focus lock?

- When the shutter button is pressed halfway, the camera focuses on the subject, and as long as the shutter button is kept pressed halfway, the focus is fixed (locked) at the same distance. This is called “focus lock”. After focusing on the subject, you can then reorient the camera while keeping the shutter button pressed halfway to compose the picture you like.

When the focus mode (page 58) is set to the 9-point focus mode ...

- A target mark  on the monitor shows the area the camera is focusing on.
- The camera automatically determines the correct focus by measuring from 9 different focus points within the shooting area. If the target mark is at a position that is different from the point you wish to focus on, you can refocus, for example, by changing the shooting angle.
- The large target mark appears when the camera focuses on a wide area in the center of the screen.

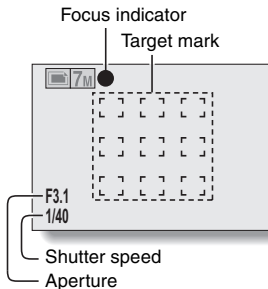

About the focus indicator

- A green focus indicator appears when the subject is successfully focused, or a red focus indicator when the camera was not able to focus the subject.

The shutter speed and aperture are displayed

- The shutter speed and aperture settings are also displayed on the monitor. You can use them as a reference when shooting.

If the motion alert icon appears...

- During still image shooting, if the shutter speed is slow and the possibility that the image may be blurred due to camera shake becomes high, the motion alert icon may appear on the monitor. In this case, use a tripod to stabilize the camera when shooting, or set the flash operation mode to automatic (page 47).
- When shooting with the fireworks  scene function, the motion alert icon always appears, but this is normal.

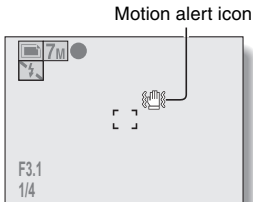

Viewing still images

The steps for viewing both single shots and sequential shots are the same.

5 Press the playback button [▶].

- If the playback button [▶] was pressed to turn the camera on, however, press the playback button [▶] for at least 1 second.
- The image most recently captured appears on the monitor.

6 View other images.

- Press the [◀] or [▶] button to display the previous or next image.

To display the previous image:

Press [◀].

To display the next image:

Press [▶].

- To return to Shooting Screen, press the playback button [▶].

<If the camera was turned on by pressing the playback button [▶]>

- When the playback button [▶] or on/off button is pressed, the camera turns off.

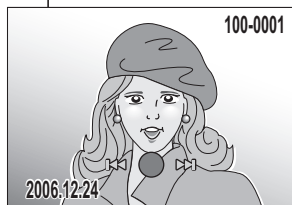
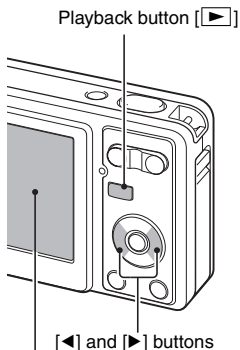

When you are finished viewing images...

- Press the on/off button to turn the camera off.

HINT

For still images with voice memo (page 44)...

- When the shutter button is pressed, the voice memo is played back.

CAPTURING AND PLAYING BACK STILL IMAGES

9-image display playback

1 Press the playback button [▶].

2 Press [W] ([📷]) on the zoom switch.
• The 9-image display appears.

3 Select the image to play back.
• Press the arrow buttons to move the orange frame to the desired image, and press the ok button. Instead of pressing the ok button, you can press [T] ([🔍]) on the zoom switch to show the image full screen.

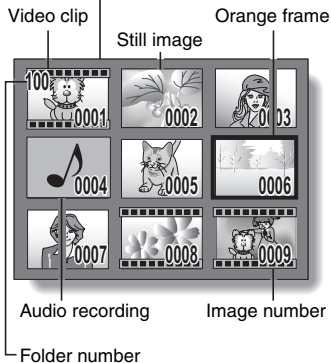
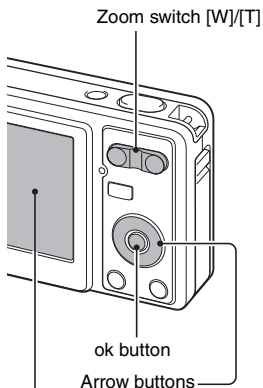

Magnifying (zooming in) the image

1 Display the image that you want to magnify.

2 Press [T] ([🔍]) on the zoom switch.

- Magnification is enabled.
- The image is magnified, and the central portion of image is displayed.
- Press the arrow buttons to view different parts of the magnified image.

To magnify:

Magnification increases with each press of [T] ([🔍]) on the zoom switch.

To return to normal size:

Magnification decreases with each press of [W] ([🔍]) on the zoom switch.

- Press the ok button to return to the normal (100%) view.

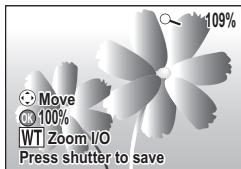

HINT

The magnified portion of the image can be saved as a separate image.

- Press the shutter button. The magnified portion is saved as a new still image.

CAPTURING AND PLAYING BACK STILL IMAGES

Erasing files

You can erase files that are stored on the card if you no longer need them. You can erase the files one at a time, or all at once.

-
- 1** To erase data from the card, perform the delete procedure with the card installed in the camera. To erase data from the camera's internal memory, remove the card before performing the delete procedure.

-
- 2** Set the camera to the playback mode, and press the delete button [🗑️].

- The Delete Screen appears.

ALL FILES:

Erases all the data.

1 FILE:

Erases one file at a time.

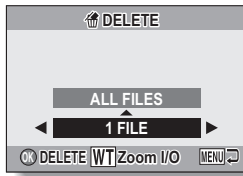

-
- 3** Delete the files.

<To delete all the files>

- ① Use the [◀] and [▶] buttons to view the images and check if it is OK to delete all the files.
- ② Press the [▲] or [▼] button to select "ALL FILES".
- ③ Press the ok button.
 - The Delete Confirmation Screen appears. To erase the files, select "YES", and press the ok button. When the file delete is completed, "No image" is shown.

<To delete one file>

- ① Use the [◀] and [▶] buttons to display the file you wish to delete.
- ② Press the [▲] or [▼] button to select "1 FILE".
 - There is no confirmation screen when deleting single files. Before pressing the ok button in step ③, please make sure that the displayed image is one you wish to delete.
- ③ Press the ok button.
 - The currently displayed file is deleted.
 - To delete other files, repeat steps ① to ③.

CAUTION

About protected images

- Files that are protected from accidental erase cannot be erased. To erase protected files, set the protect setting for the file to off (page 66), and then follow the file delete procedure.

HINT

To quickly delete a still image immediately after capturing it (direct delete)

- If you press the delete button [🗑] while the post-view image is displayed (page 83), the image is immediately deleted (still images only).
 - ① **While the post-view image is being displayed, press the delete button [🗑].**
 - The screen to confirm the deletion appears.
 - ② **Select "YES", and press the ok button.**
 - The currently shown image is deleted, and the display returns to the Shooting Screen.
 - If you do not wish to delete the image, select "NO" and press the ok button.

SHOOTING SEQUENTIAL SHOTS

When the shutter button is pressed, still images are captured in succession.

- 1** Set the camera to the sequential shots mode (page 27).

- 2** Press the shutter button to start shooting.
- Shooting sequential shots begins.

<Estimated maximum number of sequential shots>

Resolution	Max. no. of shots
7M	Approx. 6 shots
5M	Approx. 9 shots
3M	Approx. 4 shots
1M	Approx. 14 shots
0.3M	Approx. 59 shots

Sequential shots icon

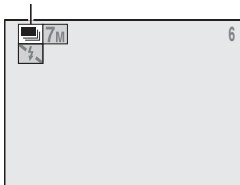

- * The maximum number of sequential shots will differ depending on the subject.
- Note that if the shutter button is released during shooting, shooting stops immediately.

HINT

About the focus when shooting sequential shots

- When sequential shots are captured, the autofocus operates when the focus lock is activated, fixing the focus.

Can the self-timer and/or flash be used?

- The self-timer and flash do not operate when shooting sequential shots.
- The following scene functions cannot be set.



VIDEO CLIP RECORDING AND PLAYBACK

Recording a video clip

1 Set the camera to the video clip recording mode (page 27).

2 Press the shutter button.

- Video clip recording begins. During recording, the length of the video clip and the remaining recording time available are shown on the monitor.
- It is not necessary to continue pressing the shutter button while shooting.

3 End the recording.

- Press the shutter button again to stop recording and save the video clip.

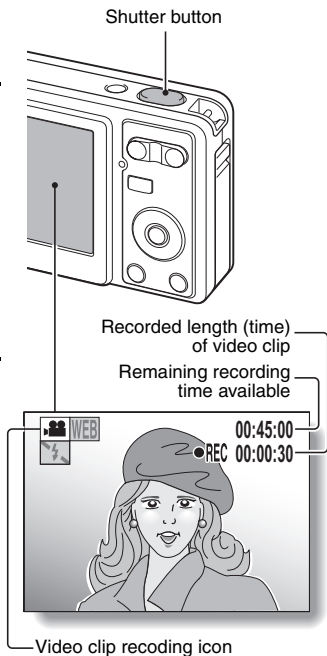

VIDEO CLIP RECORDING AND PLAYBACK

Playing back the video clip

4 Press the playback button [▶].

- If the playback button [▶] was pressed to turn the camera on, however, press the playback button [▶] for at least 1 second.
- The video clip just recorded appears on the monitor.
- Video clips are indicated by a video clip pattern along the top and bottom of the screen.

5 Press the ok button.

- Video clip playback begins.
- To stop playback, press the [▼] button.

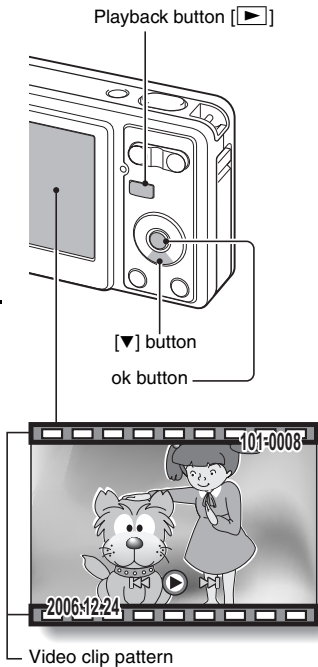

Outline of playback operation

To do this...		Do this
Stop playback		During playback, press the [▼] button
Pause		During playback, press the ok button. During accelerated or slow playback, press the [▲] button.
To extract a still image		While playback is paused, press the shutter button.
To play back one image at a time (single-frame step)	During forward playback	While playback is paused, press the [▶] button.
	During reverse playback	While playback is paused, press the [◀] button.
Slow playback	During forward playback	While playback is paused, press and hold the [▶] button.
	During reverse playback	While playback is paused, press and hold the [◀] button.
To accelerate playback	Forward playback	During forward playback, press the [▶] button. * The playback speed changes each time the [▶] button is pressed, as follows: Normal playback → 2x → 5x → 10x → 15x Press the [◀] button to resume normal playback speed.
	Reverse playback	During forward playback, press the [◀] button. * The playback speed changes each time the [◀] button is pressed, as follows: 15x ← 10x ← 5x Press the [▶] button to resume normal playback speed.
Return to normal playback speed		Press the ok button.
Adjusting the volume		Louder: During playback, press [T] on the zoom switch. Softer: During playback, press [W] on the zoom switch.

VIDEO CLIP RECORDING AND PLAYBACK

When you are finished viewing video clips...

- Press the on/off button to turn the camera off.
-

CAUTION

If no audio is heard...

The audio is not played back when the video clip is played back in the frame-by-frame, slow playback, fast playback or reverse playback mode.

CAUTION

The data for a video clip is very large.

- Therefore, be aware that if the video clip is uploaded to a computer to be played back, the computer may not be able to play back the video fast enough, making it appear jerky. (The video will always be displayed properly on the monitor.)

If video clip recording stops even when there is card memory remaining...

- Depending on the card you are using, recording may stop even if there is remaining memory in the card.
- For video clip recording, it is recommended that a high-speed memory card be used.

USING THE SCENE FUNCTION

You can select from a variety of preset settings (aperture, shutter speed, etc.) for specific shooting conditions.

- 1** Set the camera to the shooting mode (page 26), and press the [▼] button (SCENE).

- The screen to select the settings suitable for the scene (shooting conditions) appears.

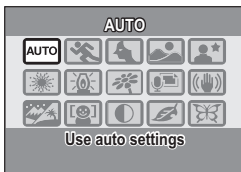











- 2** Use the arrow buttons to select the desired setting.

<Example: In the single-shot mode>

<Features of each setting>

Scene setting	Features	Shooting mode setting		
 Auto	The camera makes the optimum settings.	<input type="radio"/>	<input type="radio"/>	<input type="radio"/>
 Sports	Capture a split-second image of a fast-moving subject.	<input type="radio"/>	<input type="radio"/>	<input type="radio"/>
 Portrait	Enhance the three-dimensional feel of the subject by blurring the background.	<input type="radio"/>	<input type="radio"/>	<input type="radio"/>
 Landscape	For beautiful shots of distant scenery.	<input type="radio"/>	<input checked="" type="radio"/>	<input type="radio"/>
 Night view portrait	Photograph the subject while keeping the background night scenery.	<input type="radio"/>	<input checked="" type="radio"/>	<input type="radio"/>
 Fireworks	For capturing fireworks at night.	<input type="radio"/>	<input checked="" type="radio"/>	<input type="radio"/>
 Lamp	Used in very dark conditions.	<input type="radio"/>	<input checked="" type="radio"/>	<input type="radio"/>

USING THE SCENE FUNCTION

Scene setting	Features	Shooting mode setting		
				
 Flowers	Capture the vivid colors of flowers.	<input type="radio"/>	<input type="radio"/>	<input type="radio"/>
 Still image with audio	Shoot a still image and add a voice memo.	<input type="radio"/>	<input checked="" type="radio"/>	<input checked="" type="radio"/>
 Blur reduction	Minimize the effects of camera shake.	<input type="radio"/>	<input type="radio"/>	<input checked="" type="radio"/>
 Snow & beach	For photographing bright scenes, such as on a ski slope or at the beach.	<input type="radio"/>	<input type="radio"/>	<input type="radio"/>
 Face chaser	The subject's face is kept in focus and the exposure adjusted as the image is captured.	<input type="radio"/>	<input type="radio"/>	<input type="radio"/>
 Monochrome	Create black-and-white photos.	<input type="radio"/>	<input type="radio"/>	<input type="radio"/>
 Sepia	Create sepia-tone photos.	<input type="radio"/>	<input type="radio"/>	<input type="radio"/>
 Vivid	For more colorful images.	<input type="radio"/>	<input type="radio"/>	<input type="radio"/>

○: Available ×: Not available

*: Disabled during recording

3 Press the ok button.

- This completes the scene select setting.
- The display returns to the Shooting Screen.
- The scene function setting is shown on the monitor.

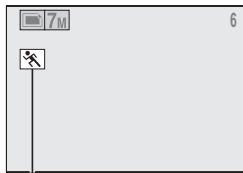

Scene function setting
(**AUTO** is not displayed)

Capture a still image with a voice memo

With the still-image-plus-audio  scene function, you can add an audio track (about 10 seconds maximum) to a captured still image. This audio track is called a “voice memo”.

1 On the screen to select the scene function settings (page 42), select , and press the ok button.

2 Press the shutter button to take the picture, then speak into the microphone.

- During recording, be careful not to obstruct the microphone with your fingers, for example.
- Audio recording begins. During recording, the length of the audio track and the remaining recording time available are shown on the monitor.
- The maximum recording time for a voice memo is about 10 seconds.
- To end the recording before 10 seconds has elapsed, press the shutter button.

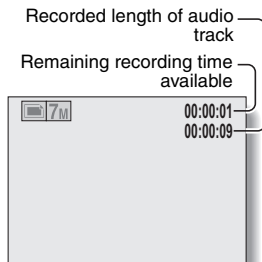

USING THE SCENE FUNCTION

How to use the face chaser feature

To attain the best possible face shots, the camera automatically focuses on the face and adjusts the exposure.

1 On the screen to select the scene function settings (page 42), select the face chaser icon , and press the ok button.

2 Aim the camera lens at the subject.

- The camera searches for the subject's face. When it detects the face, an orange frame appears.
- Do not press the shutter button halfway until the orange frame appears. The camera cannot search when the autofocus is activated.

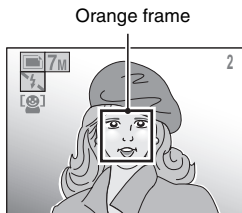



3 Press the shutter button halfway.

- The camera focuses on the subject and the exposure is adjusted.
- When the face is in focus, the orange frame changes to green.

4 Press the shutter button.

- The image is captured.

HINT

- When the focus mode is set to AF seeker , the scene function setting automatically changes to auto .

USING THE ZOOM

Your camera has two zoom functions: optical zoom and digital zoom.

1 Set the camera to the shooting mode (page 26), and point the camera lens at the subject.

2 Press the zoom switch to compose the desired image.

[T]: Zoom in on the subject.

[W]: Zoom out.

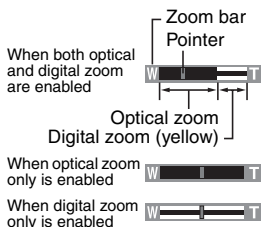
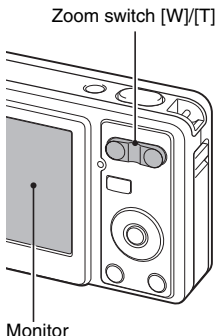

- When the zoom switch is pressed, the zoom bar appears on the monitor.
- When the optical zoom factor is at maximum, zooming stops temporarily. When [T] on the zoom switch is pressed again, the mode changes to the digital zoom mode and zooming continues.

3 Take the picture.



HINT

Can't access the digital zoom?

- The digital zoom cannot be used when the face chaser  scene function is active, or the focus mode is set to AF seeker .

Can't access the optical zoom?

- When the focus range is set to pan  or during video clip recording, the optical zoom cannot be used.

FLASH SETTING

The flash is used not only for taking pictures where there is insufficient light, but also when the subject is in shade or in backlight conditions. Your camera's flash has four modes of operation (auto mode, forced flash mode, flash off mode and red-eye reduction mode). Select the flash mode that is appropriate for the surrounding conditions. The flash can be enabled only when taking single-shot still images.

1 Set the camera to the single-shot mode (page 27), and press the [◀] (⚡) button.

- The flash menu appears.

- : The camera will detect the subject brightness and use the flash only when required. In a backlight situation, if only the center of the image is very dark, the flash will operate to compensate (auto).
- : The flash will operate with every image captured regardless of the conditions. Use this setting under backlight conditions, when the subject is in shade, under fluorescent lighting conditions, etc. (forced flash).
- : The flash will not operate even in dark situations. Use this setting when capturing an image in a location where flash photography is prohibited, or when shooting a night landscape scene (flash off).
- : The digital camera will detect the subject brightness and use the flash only when required. At this time the flash will operate in a manner that reduces the red reflection ("red-eye") in the subject's eyes (red-eye reduction).

[◀] (⚡) button

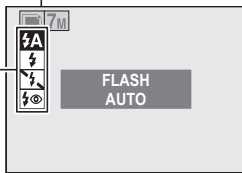
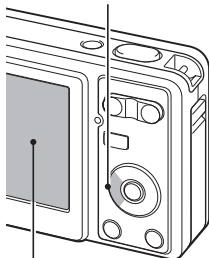

Flash menu

-
- 2** Press the [▲] or [▼] button to select the desired flash mode, and press the ok button.
-

- 3** Press the shutter button.
- The picture is snapped and the flash operates according to the selected mode.
-

HINT

When auto is selected...

- The icon indicating the flash setting is not shown on the Shooting Screen.

When auto or red-eye reduction is selected...

- When the subject is in focus, if the camera determines that the flash is necessary, a or icon appearing on the monitor indicates that the flash will operate.

SELF-TIMER

Self-timer photography is available in the single-shot mode.

1 Set the camera to the single-shot mode (page 27), and press the **[▲] (⏸)** button.

- The self-timer menu appears.

: The image is captured about 2 seconds after the shutter button is pressed.

: The image is captured about 10 seconds after the shutter button is pressed.

2 Use the **[▲]** and **[▼]** buttons to select the desired self-timer setting, and press the ok button.

- The self-timer is set, and you are returned to the Shooting Screen.

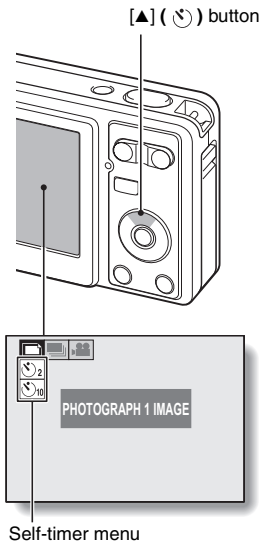

HINT

- The countdown time until shutter release is shown graphically on the monitor.

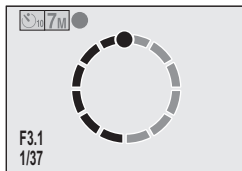

To pause or cancel the self-timer function...

- If the shutter button is pressed again before the shutter is released, the self-timer countdown temporarily stops. Press the shutter button one more time to restart the self-timer.
- To cancel self-timer photography, set the self-timer setting to off .
- After the self-timer picture is snapped, the self-timer is automatically reset to off.

When is selected...

- When the shutter button is pressed, the self-timer indicator flashes for approximately 10 seconds, after which shooting begins.
- About 3 seconds before shooting, the self-timer indicator flashes faster.

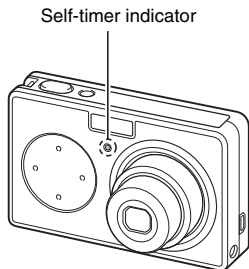

FOCUS RANGE

- 1** Set the camera to the shooting mode (page 26), and press the **[▶] (♥)** button.
- The focus range menu appears.

[PF]: The focus operates within the ranges shown below (pan).

<Still image shooting>

- At maximum aperture: 2.2 m (7.22 ft.) to ∞
- At minimum aperture: 1.3 m (4.27 ft.) to ∞

<Video clip recording>

- Wide end:
 - At maximum aperture: 40 cm (15.75 in.) to ∞
 - At minimum aperture: 30 cm (11.81 in.) to ∞
- Tele end:
 - At maximum aperture: 1.7 m (5.58 ft.) to ∞
 - At minimum aperture: 1.2 m (3.94 ft.) to ∞

[AF]: The camera automatically focuses on the subject within a range of 10 cm (3.94 in.) (Wide end) or 60 cm (23.62 in.) (Tele end) to infinity (auto).

[♥]: You can focus on a subject within a range of 5 cm (1.97 in.) (Wide) or 60 cm (23.62 in.) (Tele end) to 80 cm (31.50 in.) (macro).

[▲]: The camera focus is set to infinity.

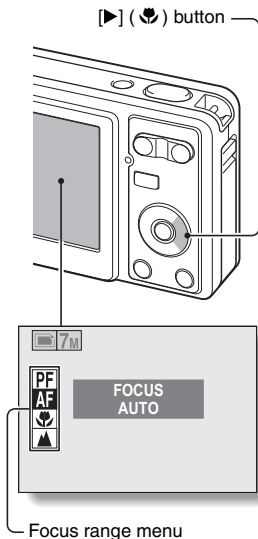

- 2** Press the **[▲]** or **[▼]** button to select the desired focus range, and press the ok button.

- The specified focus range is set, and the camera returns to the Shooting Screen.

HINT

- When the focus range is set to macro **[♥]**, the zoom is automatically set to one step from the wide end. When the focus range is set to pan **[PF]**, the zoom is automatically set to the Wide end.

ACCESSING THE RECORDING MENU

Detailed shooting settings are accessed from the Recording Menu.

- 1 Set the camera to a shooting mode (page 27).**

- 2 Press the menu button.**

- The Recording Menu corresponding to the shooting mode set in step 1 appears.
- The Recording Menu can be canceled by pressing the menu button.

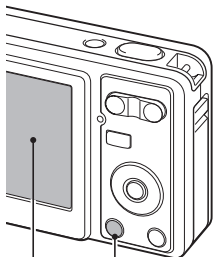

menu button

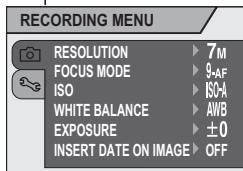

ACCESSING THE RECORDING MENU

Overview of the Recording Menu

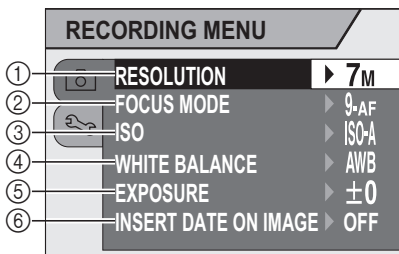

① **Resolution menu/video size menu (page 55)**

<Single-shot/sequential shots mode>

7M: Shoot at 3,072 × 2,304 pixels

5M: Shoot at 2,592 × 1,944 pixels

3M: Shoot at 2,048 × 1,536 pixels

1M: Shoot at 1,024 × 768 pixels

0.3M: Shoot at 640 × 480 pixels

<Video clip recording mode>

TV: Shoot at 640 × 480 pixels

WEB: Shoot at 320 × 240 pixels

VGS: Shoot at 160 × 120 pixels

🎤: Make an audio recording (page 56)

② **Focus mode menu (page 58)**

9-AF: 9-point focus mode

S-AF: Spot focus mode

AF: The focus follows the focus-locked subject.

③ **ISO sensitivity menu (single-shot/sequential shots mode only) (page 60)**

ISO-A: Sets the ISO sensitivity automatically (corresponds to ISO50 to 400).

50: Corresponds to ISO50

100: Corresponds to ISO100

200: Corresponds to ISO200

400: Corresponds to ISO400

800: Corresponds to ISO800

④ **White balance menu (page 61)**

AWB: The camera will determine the setting automatically.

☀️: For photography in fair weather (sunny) conditions

☁️: In overcast conditions

💡: Under fluorescent lighting

💡: Under incandescent lighting

📷: For setting the most accurate white balance

⑤ **Exposure correction menu (page 62)**

- Change the brightness of the image.

⑥ **Date imprint menu (page 63)**

- Imprint the capture date on still images.

- When you specify multiple functions that cannot be simultaneously enabled, the function which was last set becomes the active setting, and the other settings accordingly change automatically.

RESOLUTION/VIDEO SIZE SETTING

By setting the image resolution (pixels) to a higher setting, image detail is enhanced for a smoother, finer picture. However, the file size also becomes large and uses more memory. Select the resolution setting that suits your purpose.

1 Display the Recording Menu (page 52).





2 In the single-shot or sequential shots mode select “RESOLUTION”, or in the video clip recording mode select “CLIP SIZE”, and press the ok button.

- The resolution menu or video size menu appears.

<Single-shot/sequential shots mode>

- : Shoot image at 3,072 × 2,304 pixels
- : Shoot image at 2,592 × 1,944 pixels
- : Shoot image at 2,048 × 1,536 pixels
- : Shoot image at 1,024 × 768 pixels
- : Shoot image at 640 × 480 pixels

<Video clip recording mode>

- : Shoot at 640 × 480 pixels.
- : Shoot at 320 × 240 pixels.
- : Shoot at 160 × 120 pixels.
- : Make an audio recording (page 56)

3 Select the desired icon, and press the ok button.

- The selected resolution setting or video size setting is set.

Record and play back an audio file

In the video clip recording mode, your camera can make audio recordings. The audio recordings are monaural.

■ Record an audio file

1 Display the Recording Menu for the video clip recording mode (page 52).

2 Select the audio recording icon  from the video size menu, and press the ok button.

3 Press the menu button.
• The recording mode is enabled.

4 Press the shutter button.

- Audio recording begins. During recording, the length of the audio track and the remaining recording time available are shown on the monitor.
- It is not necessary to continue pressing the shutter button while recording.
- Take care not to cover the microphone with your fingers.

5 End the recording.
• Press the shutter button again to stop recording.

Recording length of audio track

Remainig recording time available

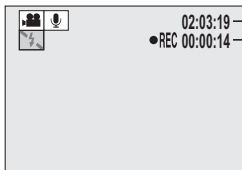

RESOLUTION/VIDEO SIZE SETTING

■ Playing back audio recordings

1 Display the desired audio data.

- A musical note graphic appears on the screen.

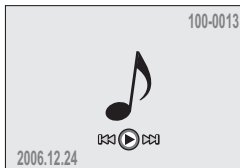

2 Play back the recording.

To do this...	Do this
Forward playback	Press the ok button.
Stop playback	During playback, press the [▼] button
Pause	During playback, press the ok button. During fast forward or fast reverse, press the [▲] button.
Fast forward	During forward playback, press the [▶] button. * The speed changes each time the [▶] button is pressed, as follows: Normal playback → 2x → 5x → 10x → 15x Press the [◀] button to resume normal speed.
Fast reverse	During forward playback, press the [◀] button. * The speed changes each time the [◀] button is pressed, as follows: 15x ← 10x ← 5x Press the [▶] button to resume normal speed.
Return to normal playback speed	Press the ok button.
Adjusting the volume	Louder: During playback, press [T] on the zoom switch. Softer: During playback, press [W] on the zoom switch.

HINT

- During 5x or faster accelerated playback, the audio is not played back.

FOCUS AREA SETTING

You can choose from different types of autofocus (still image shooting only):

9-point range finder focus:

The correct focus is determined from 9 different focus points within the shooting area visible on the monitor. When the image is focused, a target mark  appears.

Spot focus:

The camera focuses on the subject in the center of the monitor.

AF seeker:

Once the focus is locked on a subject (page 30), it follows the subject. The focus point automatically changes to remain continuously focused on a moving subject.

1 Display the Recording Menu (page 52).



2 Select "FOCUS MODE" and press the ok button.

- The focus mode menu appears.

: 9-point range finder focus is selected (page 31).

: Spot focus is selected.

: AF seeker is selected.

- When the  or  setting is selected, the focus mark appears in the center of the monitor.

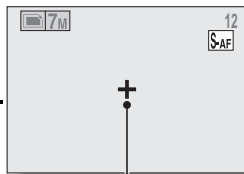

Focus mark

3 Select the desired icon, and press the ok button.

- The focus area is set.

FOCUS AREA SETTING

HINT

When spot focus is selected...

- The focus mark + appears in the center of the monitor.

When AF seeker is selected...

- The focus mark + appears in the center of the monitor.
- When the focus-lock is activated, the seeker mark appears on the focused subject.
- During focus-lock, even if the focused subject moves, the seeker mark automatically follows the subject.
- If the camera loses the focus-lock on the subject, the seeker mark disappears.
- In dark environments, the seeker mark may follow the subject more slowly.
- When the  setting is selected, the digital zoom is not available.

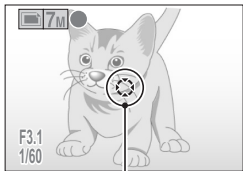

Seeker mark

ISO SENSITIVITY

With the initial settings, the ISO sensitivity is automatically set according to the brightness of the subject. However, in the single-shot mode and sequential shots mode, the ISO sensitivity can be set to a fixed setting.

1 Set the camera to the single-shot mode or the sequential shots mode, and display the Recording Menu (page 52).

2 Select “ISO” and press the ok button.

- The ISO sensitivity menu appears.

ISO-A: Sets the ISO sensitivity automatically.

50: Sets the sensitivity to ISO50 equivalent.

100: Sets the sensitivity to ISO100 equivalent.

200: Sets the sensitivity to ISO200 equivalent.

400: Sets the sensitivity to ISO400 equivalent.

800: Sets the sensitivity to ISO800 equivalent.

3 Select the desired icon, and press the ok button.

- The ISO sensitivity is set.
-

HINT

- By setting a higher ISO sensitivity, you can set higher shutter speeds and capture images in darker locations, but noise in the captured images may increase.

WHITE BALANCE

This camera automatically adjusts the white balance under most lighting conditions. However, if you want to specify the lighting conditions or change the overall tone of the image, the white balance can be manually set.

1 Display the Recording Menu (page 52).

2 Select “WHITE BALANCE” and press the ok button.

- The white balance menu appears.

: The camera will make the white balance adjustment automatically based on the natural and artificial light conditions. This is the setting used in the auto mode.

: For shooting outside on a sunny day.

: For shooting outside on a cloudy day.

: For shooting inside under fluorescent lighting.

: For shooting inside under incandescent lighting.

: For more accurate adjustment or when the light source cannot be specified (one-push).

Select the  icon from the white balance menu, fill the entire screen with a plain white paper, and press the ok button to set the white balance. To use any of the other white balance settings, proceed to step 3.

3 Select the desired icon, and press the menu button.

- This completes the white balance setting.
-

HINT

To cancel the white balance setting

- Perform steps 1 and 2, select , and then press the menu button.

EXPOSURE CORRECTION

When capturing images, you can make the image lighter or darker.

-
- 1 Point the camera lens at the subject, and display the Recording Menu (page 52).**
 - 2 Select “EXPOSURE” and press the ok button.**
 - The screen to adjust the exposure appears.
 - 3 Use the [▲] and [▼] buttons to select the desired exposure numerical value, and press the ok button.**
 - The specified exposure is set, and you are returned to the Recording Menu.
-

HINT

- The exposure correction setting returns to ± 0 after the camera is turned off.

DATE IMPRINT

You can choose to have the date the image was captured imprinted on the image.

1 Display the Recording Menu (page 52).

2 Select “INSERT DATE ON IMAGE”, and press the ok button.

- The date imprint menu appears.

ON: The date of the capture is imprinted on the image.

The DATE display is shown on the monitor.

OFF: The date of the capture is not imprinted on the image.

3 Press the [▲] or [▼] button to select the desired setting, and press the ok button.

- The date imprint mode is set, and you are returned to the Recording Menu.

HINT

About the capture date and date imprinting

- When an image is edited, the date of the image file changes to the date and time the image was edited. However, the imprinted capture date remains unchanged.

Is the sequential shots speed slow?

- When the date imprint mode is set to “ON”, the sequential shots speed may become slower.

If the imprinted date is shown as [- - - - . - - . - -] ...

- The date and time settings have not yet been completed. Set the camera to the correct date and time (page 20).

DISPLAYING THE PLAYBACK MENU

The Playback Menu is used to adjust your camera's playback settings.

- 1 Press the playback button [▶].**
 - The display changes to the Playback Screen.

- 2 Press the menu button.**
 - The Playback Menu appears.
 - The Playback Menu is canceled when the menu button is pressed.

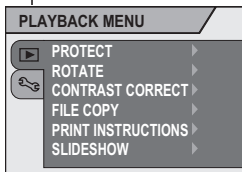
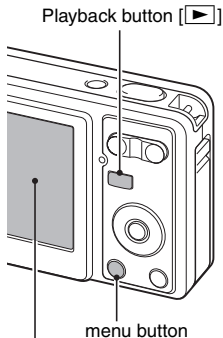

DISPLAYING THE PLAYBACK MENU

Overview of the Playback Menu

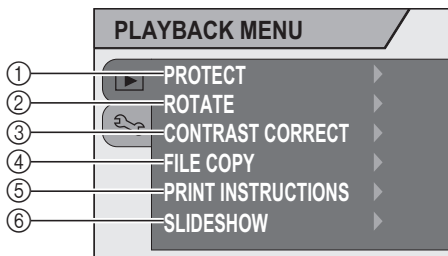

- ① **[Protect] (page 66)**
 - Protect data from accidental erasure (write protect).
- ② **[Rotate image] (page 67)**
 - Rotate still images.
- ③ **[Contrast correction] (page 68)**
 - Add contrast (light and dark) to the image to make it clearer.
- ④ **[File copy] (page 70)**
 - Copy files from the card to the internal memory, or vice versa.
- ⑤ **[Print instructions] (page 72)**
 - Specify the print settings.
- ⑥ **[Slideshow] (page 76)**
 - Play back the images in a slideshow format.

IMAGE PROTECT

Prevent accidental erasure of data.

- 1** Display the data that you want to protect from accidental erasure, and display the Playback Menu (page 64).

- 2** Select “PROTECT” and press the ok button.

- The screen to set the protect setting appears.

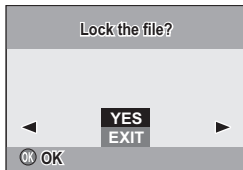

- 3** Select “YES” and press the ok button.

- The protect mode is set for the data.
- The protect mark  indicates that the data is locked.

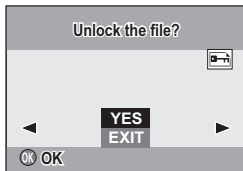

CAUTION

- Even if the protect mode is set for certain data files, they will be erased if the card is reformatted (page 91).

HINT

To select a different image in steps 2 and 3...

- Press the [◀] or [▶] button.

To cancel the protect mode for an image...

- Display the desired data and repeat steps 1 to 3.

ROTATE IMAGE

Captured still images can be rotated to the correct orientation for viewing.

1 Display the image you wish to rotate, and display the Playback Menu (page 64).

2 Select “ROTATE” and press the ok button.

- The screen to rotate the image appears.
-

3 Select “YES” and press the ok button.

- Each time the ok button is pressed, the image is rotated another 90 degrees.
-

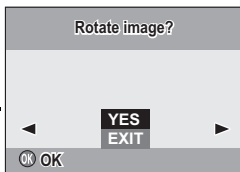

HINT

- On the 9-image display playback, rotated images are shown in their original orientation.
- An image for which the protect (locked) mode has been set cannot be rotated.

CONTRAST CORRECTION

Add contrast (light and dark) to an image to make it clearer.

- 1** Display the image to be modified, and display the Playback Menu (page 64).
-

- 2** Select “**CONTRAST CORRECT**”, and press the ok button.

- The Contrast Correction Screen appears.

YES:

Proceed with the contrast correction.

EXIT:

Return to the Playback Menu.

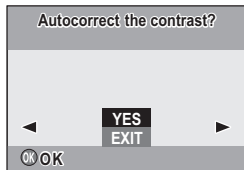

- 3** Select “**YES**”, and press the ok button.

- Image processing begins.
- During image processing, “Processing” is shown on the screen.
- When processing is completed, the modified image is shown. Check the image to see if the post-processing result is satisfactory.

CONTRAST CORRECTION

4 If the modified image is satisfactory, press the ok button.

- The screen to save the corrected image appears.
- To discontinue the procedure, press the menu button. The modified image is discarded, and you are returned to the Contrast Correction Screen.

SAVE AS NEW:

The modified image is saved as a separate image, and the original image is preserved.

OVERWRITE FILE:

The original file is deleted, and only the modified image is saved.

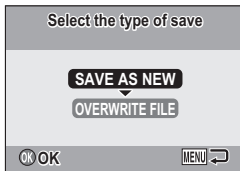

5 Select the desired method to save the modified image, and press the ok button.

- The modified image is saved, and you are returned to the Contrast Correction Screen.

HINT

Concerning the date and time information for the modified image

- The date display that is shown when an edited image is played back is the date that the image was saved after it was modified.

Can't overwrite?

- Images for which the protect mode (page 66) is set cannot be overwritten. The modified image can be saved as a new image.

COPY DATA

Images recorded in the camera's internal memory can be copied to the card, and likewise from the card to the internal memory.

1 Insert the card in the camera (page 16).

2 Display the Playback Menu (page 64).

3 Select "FILE COPY" and press the ok button.
• The screen to copy files appears.

4 Select the copy direction.

INT MEM → CARD:

Copy image data from the internal memory to the card.

CARD → INT MEM:

Copy image data from the card to the internal memory.

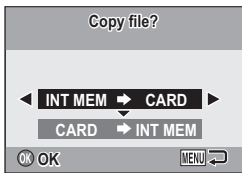

* If no card is set in the camera, you cannot copy data.

COPY DATA

5 Press the ok button.

- The screen to select the type of copy appears.
- The copy source image is shown in the background on the screen.

COPY SINGLE:

Copy the data for one image.

COPY ALL:

Copy all the data from the copy source to the copy destination.

EXIT:

You are returned to the screen to copy files (step 3).



6 Select the desired type of copy.

<When selecting COPY SINGLE>

- ① Press the [◀] or [▶] button to display the image you wish to copy.
- ② Press the [▲] or [▼] button to select "COPY SINGLE".

<When selecting COPY ALL>

- ① Press the [▲] or [▼] button to select "COPY ALL".

7 Press the ok button.

- The files are copied.

PRINT SETTINGS

In addition to using your printer to print out still images captured with your camera, as with conventional film, you can have prints made at shops offering digital print services. Moreover, this camera is DPOF-compatible, so you can use the camera to specify the number of prints, or whether or not the date is displayed on the print.

Display the screen to set the print settings

1 Display the Playback Menu (page 64).

2 Select “PRINT INSTRUCTIONS” and press the ok button.

- The screen to set the print settings appears.

EACH IMAGE:

The print settings are specified for each individual image.

ALL IMAGES:

The specified print settings apply to all the still images on the card.

ALL CLEAR:

Clear all the print settings.



HINT

About the DPOF format

- DPOF (Digital Print Order Format) is a print order format. You can connect your camera to a DPOF-compatible printer to produce your prints. You can also set the print settings (page 111) for the desired images, and then have the reserved images printed automatically.

About the finished prints

- Images that have been rotated will be printed in their original orientation.
- The quality of the print output will differ depending on the print service and printer used.

CAUTION

- It is not possible to set the print settings when there are 10,000 or more files saved on the card.

PRINT SETTINGS

Specifying date imprinting and number of prints

You can specify print settings for each individual image (EACH IMAGE), or apply the print settings to all the images on the card (ALL IMAGES).

1 Display the screen to set the print settings (page 72).

2 Select EACH IMAGE or ALL IMAGES.

EACH IMAGE:

The set print settings are applied only to the image currently displayed.

ALL IMAGES:

The set print settings are applied to all the still images on the card.



3 Press the ok button.

- The Date/Copies Print Screen appears.
- If "EACH IMAGE" was selected, press the [◀] or [▶] button to display the desired image to print.
- The print settings for the currently displayed image are shown in the upper left area of the monitor. You can press the [◀] or [▶] button to confirm the print settings for each image.

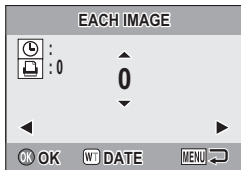

4 Specify the number of prints and whether the date is imprinted.

- Please specify the number of prints before setting the date imprint setting. The date imprint setting cannot be set until the number of prints has been entered.

<Specifying the number of prints>

- Press the [▲] or [▼] button to specify the number of prints.
 - Press the [▲] or [▼] button until the desired number of prints is displayed.

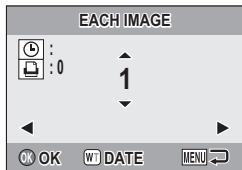

<Specifying dated prints>

- Press [W] on the zoom switch to add a check mark (✓) next to the  icon.

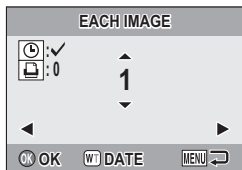

5 Press the ok button.

- This completes the settings for the number of prints and date imprinting.
- If you press the menu button, you are returned to the screen to set the print settings (step 1).

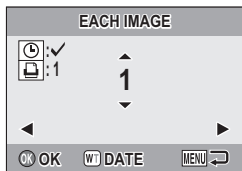

CAUTION

- Do not specify dated prints for images that were captured with the date imprint function (page 63) set to ON, or else the date will appear on the photo print twice.

PRINT SETTINGS

Clearing all the print settings

Delete the print settings for all images.

1 Display the screen to set the print settings (page 72).

2 Select "ALL CLEAR".



3 Press the ok button.

- The Confirm All Clear Screen appears.

YES: Clear the print settings for all images.

EXIT: Cancel the clear procedure and return to the screen to set the print settings.

4 Select "YES", and press the ok button.

- All the print settings are cleared and you are returned to the Playback Menu.

SLIDESHOW PLAYBACK

1 Display the Playback Menu (page 64).

2 Select "SLIDESHOW" and press the ok button.

- The screen to set the slideshow appears.

TIME: Adjust the transition speed (the period that an image is displayed before it changes to the next image).

EFFECT: Select a transition effect as an image changes to the next image.

BGM: Specify the settings for playing background music during slideshow playback.

START: Begin slideshow playback.

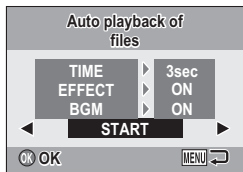

<Changing the slideshow controls>

- ① Select one of the slideshow controls, and press the ok button.
- ② Press the [▲] or [▼] button to change the setting.
- ③ Press the ok button.

3 Select "START", and press the ok button.

- Slideshow playback starts.
- To stop slideshow playback, press the ok button or menu button.

HINT

- Audio data is not played during slideshow playback.

DISPLAYING STILL IMAGE PROPERTIES

The settings that were active when a still image was captured can be displayed (Information Screen).

1 Display the desired still image.

2 Press the ok button.

- The Information Screen appears.
- If the ok button is pressed again, the Information Screen is canceled.

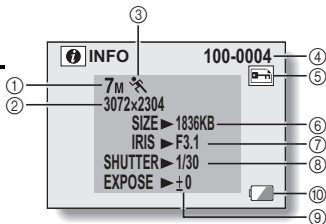

- ① Resolution setting
- ② Resolution
- ③ Scene function setting
- ④ Image number
- ⑤ Protect setting
- ⑥ File size
- ⑦ Aperture value
- ⑧ Shutter speed
- ⑨ Exposure correction setting
- ⑩ Remaining battery power

DISPLAYING THE OPTION MENU

The Option Menu is used to adjust various camera settings.

1 Display the Recording Menu or Playback Menu.

- Recording Menu, see page 52
 - Playback Menu, see page 64
-

2 Press the [▲] or [▼] button to select the option tab .

- The Option Menu appears.

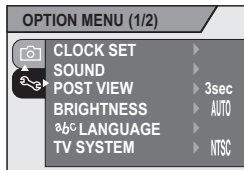

To exit the Option Menu

To return to the Shooting Screen or Playback Screen

→ Press the menu button.

To return to the Recording Menu or the Playback Menu

→ With the option tab  selected, press the [▲] or [▼] button.

DISPLAYING THE OPTION MENU

Overview of the Option Menu

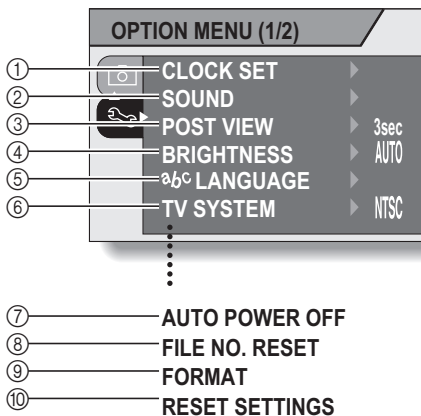

- ① **[Date and time setting] (page 20)**
 - Set the camera's internal clock.
- ② **[Sounds] (page 81)**
 - Adjust the sounds produced by the camera.
- ③ **[Post-view] (page 83)**
 - Specify how long a still image is displayed on the monitor after it is captured.
- ④ **[LCD brightness] (page 84)**
 - Adjust the brightness of the monitor.
- ⑤ **[^{abc} language] (page 85)**
 - Select the language in which the monitor messages are displayed.
- ⑥ **[TV system setting] (page 86)**
 - Select the type of TV signal that is output from the camera's A/V OUT terminal.
- ⑦ **[Auto power off] (page 87)**
 - Specify the time elapsed before the auto power off function operates to turn the camera off.
- ⑧ **[File number reset] (page 88)**
 - Set the file number reset function to ON or OFF.
- ⑨ **[Format] (page 91)**
 - Reformat the camera's internal memory or the card installed in the camera.
- ⑩ **[Reset camera settings] (page 93)**
 - Reset the camera to the factory-preset settings.

- ⑦ through ⑩ are displayed when you press the [▲] or [▼] button to scroll.

SOUNDS

Set the sounds that are produced by the camera.

1 Display the Option Menu (page 78).

2 Select "SOUND" and press the ok button.

- The screen to set the sounds appears.

OPERATION VOL:

Volume setting for all camera buttons.

TURN ON/OFF:

Mute or enable the sound that is produced when the camera is turned on or off.

SHUTTER:

Select the sound that is produced when the shutter button is pressed.

KEY SW:

Select the sound that is produced when a camera button (ok button, menu button, etc.) is pressed.

PLAY VOLUME:

Adjust the volume for playing back video clips and audio files.

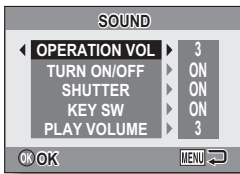

3 Select the desired item, and press the ok button.

4 Press the [▲] or [▼] button to change the setting.

<If “TURN ON/OFF”, “SHUTTER” or “KEY SW” is selected>

- The menu to enable or disable each operation sound appears.
ON: Activates the sound.
OFF: Deactivates the sound.

<If “OPERATION VOL” or “PLAY VOLUME” is selected>

- The screen to select the volume setting appears.
 - You can select a volume setting from 1 (minimum) to 5 (maximum).
 - If “OFF” is selected, no sound is produced.
-

5 Press the ok button.

- The sound settings are completed.
- To return to the Option Menu, press the menu button.

POST-VIEW SETTING

Specify the duration that the captured image appears on the monitor (post-view) after the shutter button is pressed.

1 Display the Option Menu (page 78).

2 Select "POST VIEW" and press the ok button.

- The Post View Menu appears.
- When "OFF" is selected, the post-view image is not displayed.

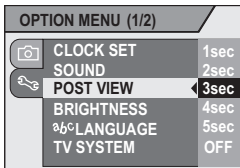

3 Select the desired setting, and press the ok button.

- This completes the post-view setting.

ADJUST THE MONITOR BRIGHTNESS

The brightness of the monitor is adjustable. Adjust the brightness to the optimum readability in the ambient light.

1 Display the Option Menu (page 78).

2 Select “BRIGHTNESS” and press the ok button.

- The Monitor Brightness Menu appears.
- When set to “AUTO”, the illumination sensor (page 12) detects the ambient brightness and automatically adjusts the brightness of the monitor accordingly.

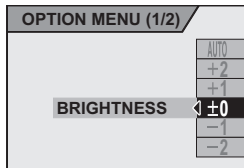

3 Select the desired setting, and press the ok button.

- This completes the monitor brightness setting.

SCREEN LANGUAGE

You can set the monitor of your camera to display the messages in any one of several languages.

1 Display the Option Menu (page 78).

2 Select “ LANGUAGE” and press the ok button.

- The screen to select the display language appears.



3 Select the desired language, and press the ok button.

- The selected display language is set.

TV SYSTEM SETTING

Specify the type of image signal that is output from your camera's A/V OUT terminal.

1 Display the Option Menu (page 78).

2 Select "TV SYSTEM" and press the ok button.

- The TV System Menu appears.

NTSC:

Outputs NTSC video signals.

PAL:

Outputs PAL video signals.

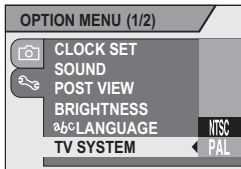

3 Select the desired setting, and press the ok button.

- The selected TV system is set.

HINT

If no image appears on the TV...

- If the TV system setting is not correct for the connected equipment, no image will appear on the TV.

AUTO POWER OFF FUNCTION

Your camera has an “auto power off” function whereby the power automatically turns off after a specified period of inactivity. The auto power off function works to conserve the battery pack power when the camera is not being used, or to prevent the battery pack from dying if the camera has accidentally been left on. You can specify the elapsed time (standby time) before the auto power off function operates to turn the camera off.

1 Display the Option Menu (page 78).

2 Select “AUTO POWER OFF” and press the ok button.

- The screen to set the standby time appears.

RECORDING:

Set the standby time for the shooting mode.

PLAYBACK:

Set the standby time for the playback mode.



3 Select the desired option, and press the ok button.

- The Standby Time Menu appears.

4 Press the [▲] or [▼] button to select the standby time.



5 Press the ok button.

- The auto power off function is set.
- To return to the Option Menu, press the menu button.

<Example: When
“RECORDING” is selected>

FILE No. RESET FUNCTION

If a newly formatted (page 91) card is used, the file name (image number) of the captured image automatically begins from 0001. If the card is subsequently reformatted, or if a different reformatted card is used, the file names again begin from 0001. This is because the file number reset function is set to "ON", and consequently it results in more than one card containing images with the same numbers. By setting the file number reset function to "OFF", even if the card is reformatted or the card is replaced with another card, the consecutive numbering of file names continues from the last number recorded by the camera.

<File number reset function "ON">

	File name (image number)
Card A	0001, 00020012, 0013

⋮
Replace card



Card B	0001, 00020012, 0013
--------	----------------------------

<File number reset function "OFF">

	File name (image number)
Card A	0001, 00020012, 0013

⋮
Replace card



Card B	0014, 0015 0025, 0026
--------	-----------------------------

FILE No. RESET FUNCTION

- If Card B already has image data in it when it replaces Card A, file names are assigned as follows.

When the highest image number on Card B (before replacing) is lower than the highest image number on Card A: the file name of the next recorded image continues from last file name recorded on Card A.



When the highest image number on Card B (before replacing) is higher than the highest image number on Card A: the file name of the next recorded image continues from last file name recorded on Card B.



HINT

What about the internal memory?

- The file number reset function works the same for the internal memory.

1 Display the Option Menu (page 78).

2 Select “FILE NO. RESET” and press the ok button.

- The File Number Reset Menu appears.
ON:
The file number reset function is “ON”.
OFF:
The file number reset function is “OFF”.

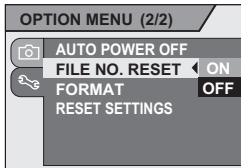

3 Select “OFF”, and press the ok button.

- The file number reset function was set to OFF.

HINT

- Until the file number reset function is turned “ON”, consecutive file names are assigned. It is recommended that the file number reset function be returned to “ON” at the end of each photography session.

INITIALIZING THE CARD MEMORY AND INTERNAL MEMORY

A card must be formatted with this camera:

- After purchasing, when used for the first time, or
- If it was formatted using a personal computer or another digital camera.

The card cannot be reformatted if the lock switch is set to the "LOCK" position. Proceed with the reformat procedure after setting the lock switch to the unlocked position.

1 To reformat a card, install it in the camera. To reformat the camera's internal memory, remove the card from the camera.

2 Display the Option Menu (page 78).

3 Select "FORMAT" and press the ok button.

- The screen to begin formatting appears.

FORMAT:

A normal formatting is executed.

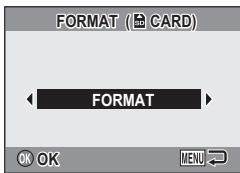

<With card installed>

4 Press the ok button.

- The screen to confirm formatting appears.

5 Select “YES”, and press the ok button.

- Formatting begins.
- During formatting, “Formatting” and “do not power off” are shown on the monitor.

CAUTION

Caution during reformatting

- Please do not turn off the camera or insert/remove the card while the card is being formatted.

Reformatting erases the data

- When the card or internal memory is initialized, all the recorded data is erased. Protected data is also erased, so before reformatting a card, any data you want to keep should be copied to your personal computer’s hard disk or other storage medium.

Caution regarding disposing/transferring the card (recovering data from a reformatted card)

- If a card is reformatted or the data is erased from the card using the camera or a computer, the card’s control data may be merely modified and the data itself may not be completely erased from the card.
- If you are disposing of a card or are transferring the card to someone else, it is recommended that you physically destroy it, or use commercially available software for erasing card data.

HINT

To cancel reformatting

- In step 5, select “EXIT”, and press the ok button.

RESETTING THE CAMERA SETTINGS

Reset the camera to the factory-preset settings.

1 Display the Option Menu (page 78).

2 Select “RESET SETTINGS” and press the ok button.

- The Reset Settings Menu appears.

YES:

Reset to the factory-preset settings.

NO:

Do not change the settings, and return to the Option Menu.

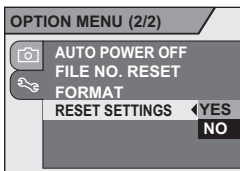

3 Select “YES”, and press the ok button.

- The camera settings are reset to the factory-preset settings.
-

HINT

- Note that the following settings do not change with this procedure:
 - Date and time setting**
 - Language setting**
 - TV system setting**
 - File No. reset setting**

CHECKING THE REMAINING INTERNAL MEMORY AND CARD MEMORY

You can check the possible number of images, audio recording time and video clip recording time remaining on the card. For a table showing the maximum number of images and recording time for the internal memory and for a specific card, please see “Possible Number of Images/Video Recording Time/Audio Recording Time” on page 131.

1 Press the on/off button to turn the camera on.

<To check the remaining number of still images>

Set the shooting mode to the single-shot or sequential shots mode (page 27).

<To check the remaining video clip recording time>

Set the shooting mode to the video clip recording mode (page 27).

- The remaining recording time is shown on the monitor.
- The remaining number of images and video recording time will differ depending on the resolution and video size settings.

Remaining number of images

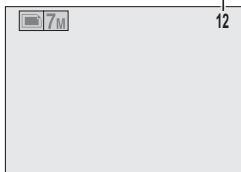

<Still Image Shooting Screen>

Remaining recording time

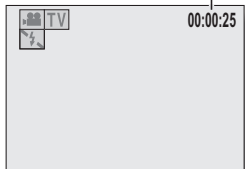

<Video Clip Recording Screen>

CHECKING THE REMAINING INTERNAL MEMORY AND CARD MEMORY

For audio data

- 1 Set the camera to the audio recording mode (page 56).**
 - The remaining audio recording time is shown.

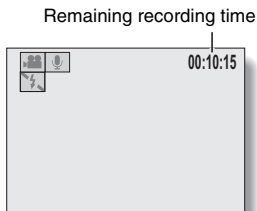

HINT

- When the remaining number of images or the remaining video recording time is "0", you cannot capture any more images. To capture more images, either install a new card, or save the images to a computer and then erase them (page 35) from the card.
- When the remaining number of images or the remaining video recording time is "0", it may be possible to capture a few more images by changing the resolution setting or video clip mode setting (page 55).
- The maximum number of images is 9,999, and the maximum video/audio recording time is 99:59:59. Note that if a large-capacity card is used, the remaining number of images or recording time may not be correctly displayed.

CHECKING THE REMAINING BATTERY CHARGE



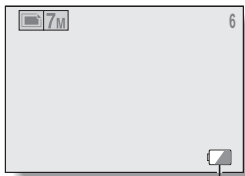

When using the battery pack, the remaining battery pack charge can be checked on the monitor. Make sure to check this indicator before capturing an image. For an indication of the possible length of time for battery pack operation, see page 130.

1 Press the on/off button to turn the camera on.

- The battery pack remaining charge indicator appears in the lower right corner of the monitor.
- Due to the battery pack characteristics, when the ambient temperature is low,  may appear early for an incorrect indication of the remaining charge. Also, depending on the conditions of use of the camera or the ambient conditions (temperature, etc.), the indicated remaining charge may change. Therefore, this indication can only be used as a general approximation of the remaining charge.



Battery pack remaining charge indicator

Battery pack remaining charge indicator	Battery remaining charge
No indication, or 	Approx. full. ( appears only in certain operation modes.)
	Power is low.
	It will soon be impossible to capture or play back images.
	If this icon flashes when the shutter button is pressed, images cannot be captured. Recharge the battery pack.

CHECKING THE REMAINING BATTERY CHARGE

HINT

- If any data is present, you can also check the remaining battery pack charge on the Information Screen (page 77).
- Battery life may differ even among battery packs of the same type.
- Depending on the usage of the camera (such as the number of times the flash is used, etc.) or the ambient temperature (temperatures below 10°C [50°F]) the number of images that can be saved on a fully charged battery pack will vary greatly.
- It is recommended that you prepare an extra battery pack(s) when taking pictures at a wedding or while traveling, for example, so you don't miss capturing images of important moments due to the battery pack power running out. The same is recommended for taking photos in cold environments. (In a ski area, for example, the battery pack can be kept warm in your pocket until ready to use.)

CONNECTING TO A TV

Connect the supplied video interface cable from the A/V OUT terminal on the digital camera to the AUDIO and VIDEO input terminals on the TV.

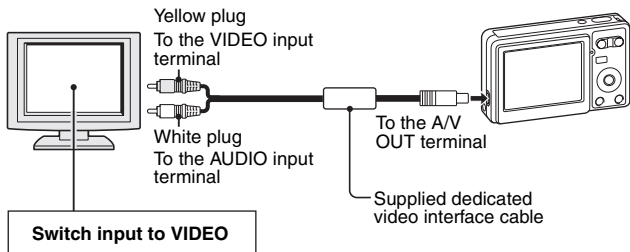

Playback

- After connecting the digital camera to the television, set the TV input switch to VIDEO input.
- When a dedicated video interface cable is connected, no image appears on the camera's monitor.
- The playback method is the same as when viewing images on the camera's monitor.
- The same playback procedure as when playing back with the camera is used to play back voice memos and audio recordings as well.

Voice memo playback: see page 32

Audio playback: see page 57

CAUTION

Insert and pull out the cable carefully

- When connecting the cables, make sure that the cable plugs are correctly oriented and that they match the shapes of the terminal sockets on the devices. Push the plugs in straight when connecting them. If undue force is used to connect a cable, it may permanently damage the connector pins in the terminal socket.
- Do not use excessive force when connecting and disconnecting cables.

CONNECTING TO A COMPUTER

The camera can be used as a card reader if it is connected to a computer.

Cautions when mounting your camera as a removable disk

- Do not alter files or folders in your camera in any way. Doing so may result in your camera not recognizing that data.
If you want to edit files, first copy them to your computer's hard drive.
- Cards formatted on your computer cannot be used by your camera. Format all cards to be used by your camera with your camera.

Operating environment

Windows

A computer with a standard-equipped USB port, and preinstalled with Windows 2000, Me or later is required. Correct operation cannot be guaranteed for models with upgraded Windows systems.

Macintosh

A model with a standard-equipped USB port, and preinstalled with Mac OS 9.0, 9.1, 9.2, Mac OS X 10.1 or later is required.

Data file formats

The format of the files saved on the card and the method in which the file names are determined are explained below.

Type of data	Data format	File name structure
Still image/ sequential shots data	JPEG	File name begins with UNI_. Extension is ".jpg". UNI_****.jpg
Voice memo data	WAVE	Same file name as corresponding still image data. Extension is ".wav". UNI_****.wav
Video clip data	QuickTime Movie	File name begins with UNI_. Extension is ".mov". UNI_****.mov*
Audio recording data	WAVE	File name begins with UNI_. Extension is ".wav". UNI_****.wav*

* Consecutive numbers assigned in the order the data was saved.

Configuration of directories in the card

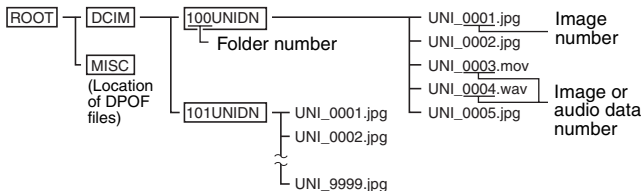

- * Up to 9,999 files can be stored in folder 100UNIDN. If more image or audio files are made, a folder named 101UNIDN is created, and they will be stored in there. New folders will then be named in sequence, i.e., 102UNIDN, 103UNIDN, etc.

HINT

About video clip data recorded with this camera

- You can use Apple's QuickTime 3 or later version to play back video clips on a computer.
- QuickTime can be downloaded free of charge from the Apple Computer website.
<http://www.apple.com/quicktime/download/win.html>
(The website URL may change.)

About file names when the card is replaced...

- If the file number reset function is set to off, even when the card is replaced, consecutive numbering of folder numbers and file names continues from the previously installed card (see page 92).

CAUTION

If you intend to view the images on the camera, do not use a computer to rewrite the card data.

- If the folders, file names, or their configuration is modified using a personal computer, it will be impossible to play back the data using the camera, and the camera may not operate properly.

CONNECTING TO A COMPUTER

Setting to the card reader mode

- 1** Start your computer, use the supplied USB interface cable to connect your camera to the computer.
- Connect the camera's USB/VIDEO terminal to the computer's USB connector.
 - The USB Connection Screen appears on the camera's monitor.

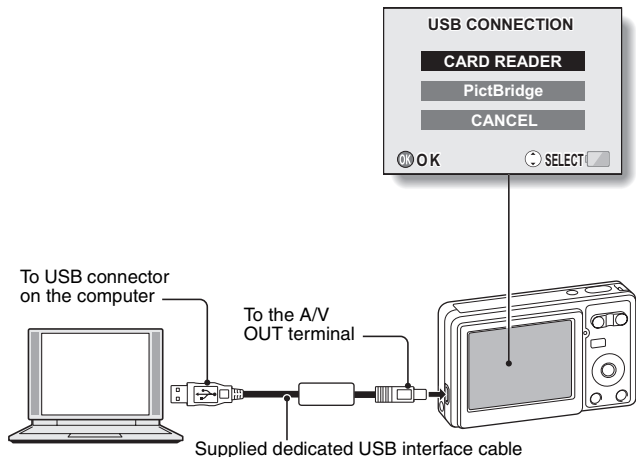

2 Select “CARD READER”, and press the ok button.

CAUTION

Insert and pull out the cable carefully

- When connecting the cables, make sure that the cable plugs are correctly oriented and that they match the shapes of the terminal sockets on the devices. Push the plugs in straight when connecting them. If undue force is used to connect a cable, it may permanently damage the connector pins in the terminal socket.
- Do not use excessive force when connecting and disconnecting cables.
- Please connect the dedicated USB interface cable to your computer's USB connector. Do not connect it to the USB port on your monitor or keyboard, or to the USB hub.

CONNECTING TO A COMPUTER

For Windows XP users

Mounting your camera

- 1 Set the camera to the card reader mode (page 101).**
 - The message [Found New Hardware] appears in the task tray, showing that the camera is recognized as a drive.
 - The card is recognized (mounted) as a disk, and the [Removable disk (E:)] window opens.
 - * The drive name (E:) may be different on your computer.
-

- 2 Select an action.**
 - Select the desired procedure from the [UDC-7M (E:)] window.
-

Dismounting the camera

CAUTION

- To disconnect your camera, be sure to follow the procedure below. Failure to follow this procedure may cause faulty operation of your computer or loss of card data.
-

- 1 Left-click on the icon for safely removing hardware.**
 - A list appears showing the devices connected to the computer's USB connector.
-

- 2 Left-click on the camera drive (E:).**
 - The camera can now be disconnected.
 - * The drive name (E:) may be different on your computer.
-

For Windows Me/Windows 2000 users

Mounting your camera

- 1 Set the camera to the card reader mode (page 101).**
 - The camera is recognized as a drive, and [Removable disk (E:)] appears in the [My Computer] window.
 - * The drive name (E:) may be different on your computer.
 - The card is recognized (mounted) as a disk.
 - Double-click on the [Removable disk (E:)] icon in [My Computer], and you can process the contents of the card installed in your camera exactly like you would the data in the other computer drives.

Dismounting the camera

CAUTION

- To disconnect your camera, be sure to follow the procedure below. Failure to follow this procedure may cause faulty operation of your computer or loss of card data.

-
- 1 Left-click on [Unplug or Eject Hardware] in the task tray.**
 - A list appears showing the devices connected to the computer's USB connector.
 - 2 Left-click on the camera drive (E:).**
 - * The drive name (E:) may be different on your computer.
 - The [Safe to Remove Hardware] dialog box will open.
 - 3 Click on the [ok] button.**
 - You can now disconnect the camera.
-

CONNECTING TO A COMPUTER

For Mac OS 9.xx users

Mounting your camera

- 1 Set the camera to the card reader mode (page 101).**
 - The camera is recognized as a drive and appears as an icon named [Untitled] on the Desktop.
 - Double-click on the [Untitled] icon, and you can process the contents of the card installed in your camera exactly like you would the data in the other computer drives.

Dismounting the camera

CAUTION

- To disconnect your camera, be sure to follow the procedure below. Failure to follow this procedure may cause faulty operation of your computer or loss of card data.

-
- 1 Drag the [Untitled] icon for your camera on the Desktop to the trashcan.**
 - The [Untitled] icon disappears from the Desktop.
 - You can now disconnect your camera.

For Mac OS X users

Use the same mounting and dismounting procedure as for the Mac OS 9.xx. However, if an application which automatically recognizes camera images is installed, it will be activated.

DIRECT PRINTING

Your camera supports the PictBridge function. By connecting the camera directly to a PictBridge-enabled printer, the camera's monitor can be used to select images and initiate printing (PictBridge printing).

Print preparations

- 1** Insert the card containing the images you wish to print in the camera.
- 2** Turn the printer on, use the supplied USB interface cable to connect the camera to the printer.
 - Connect the camera's A/V OUT terminal to the printer's USB connector.
 - The USB Connection Screen appears on the camera's monitor.

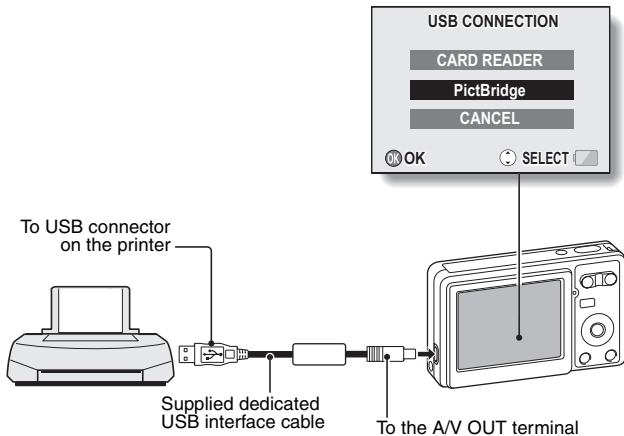

DIRECT PRINTING

3 Select “PictBridge”, and press the ok button.

- The screen to select the images to print appears.

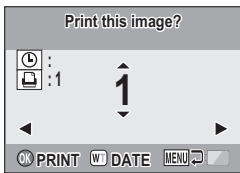

CAUTION

Caution when connecting a printer

- If the power to the printer is turned off while it is connected, the camera may not operate correctly. If the camera does not operate correctly, disconnect the USB interface cable, turn off the camera, and then reconnect the cable.
- During PictBridge printing, the camera's button operation response is slower.
- If the camera is powered by the battery pack for printing, make sure that the remaining battery charge is sufficient.

Insert and pull out the cable carefully

- When connecting the cables, make sure that the cable plugs are correctly oriented and that they match the shapes of the terminal sockets on the devices. Push the plugs in straight when connecting them. If undue force is used to connect a cable, it may permanently damage the connector pins in the terminal socket.
- Do not use excessive force when connecting and disconnecting cables.

To select one image and print it (print selected image)

Procedure to select one still image and print it.

1 Complete the printing setup (page 106).

2 Press the [◀] or [▶] button.

- Display the image you wish to print.



DIRECT PRINTING

3 Specify the number of prints or date-imprinted prints.

<Specifying the number of prints>

- Press the [▲] or [▼] button to specify the number of prints.
 - Press the [▲] or [▼] button until the desired number of prints is displayed.

<Specifying dated prints>

- Press [W] on the zoom switch to add a check mark (✓) next to .

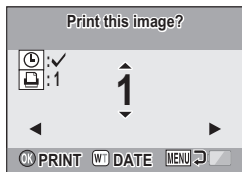

4 Press the ok button.

- Printing begins.

HINT

To cancel printing

- ① During printing, press the [▼] button.
 - The Confirm Cancel Printing Screen appears.
- ② Select "YES", and press the ok button.
 - If "EXIT" is selected and the ok button is pressed, printing resumes.

CAUTION

- Do not specify dated prints for images that were captured with the date imprint function (page 63) set to ON, or else the date will appear on the photo print twice.

To print all the images (all images)

Print all of the images.

1 Complete the printing setup (page 106).

- 2 Press the menu button.**
- The PictBridge Menu appears.

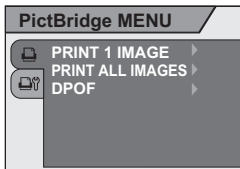

- 3 Select PRINT ALL IMAGES, and press the ok button.**
- The Print All Images Screen appears.

4 Specify the number of prints or date-imprinted prints.

<Specifying the number of prints>

- Press the [▲] or [▼] button to specify the number of prints.
 - Press the [▲] or [▼] button until the desired number of prints is displayed.

<Specifying dated prints>

- Press [W] on the zoom switch to add a check mark (✓) next to .

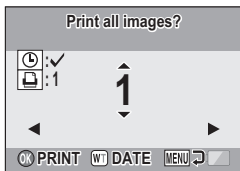

- 5 Press the ok button.**
- Printing begins.

CAUTION

Printing is not possible if there are more than 999 still images in the card or internal memory.

- Delete unwanted images before printing.

DIRECT PRINTING

To print the images that are set to print (print reserved images)

Procedure to print all the images that are set to print.

1 Make the print settings (page 72), and complete the printing setup (page 106).

2 Press the menu button.

- The PictBridge Menu appears.

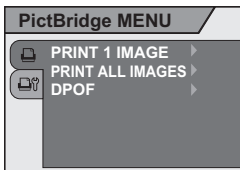

3 Select DPOF, and press the ok button.

- The Print Scheduled Images Screen appears.
- An image that is set to print (page 72) is displayed.

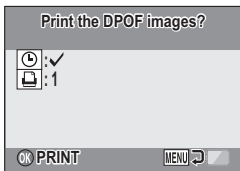

4 Press the ok button.

- Printing begins.
- Printing begins about 1 minute after the ok button is pressed.

HINT

- In step 3, if you press the [◀] or [▶] button, you can confirm the images that are set to print and their DPOF settings.

CAUTION

- Reserved images printing is not possible if a printer is used that does not support your camera's DPOF function.
- Multi-prints are not possible.

To change the printer settings and print images (change printer settings)

Images are printed according to settings specified by the camera, such as paper type, size, layout, printing quality, etc.

1 Complete the printing setup (page 106).

2 Press the menu button.

- The PictBridge Menu appears.

3 Select the printer settings tab , and press the ok button.

- The Printer Settings Menu appears.

DATE STAMP:

Print the date the photo was taken.

MEDIA TYPE:

Specify the type of paper used for printing.

PAPER SIZE:

Specify the size of paper used for printing.

LAYOUT:

Specify how the images are to be arranged on the paper.

QUALITY:

Select the print quality for the images.

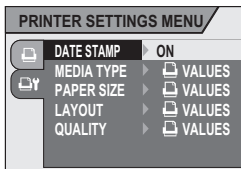

DIRECT PRINTING



4 Adjust the printer settings.

- ① Use the arrow buttons to select a printer setting parameter, and press the ok button.
 - The screen to set the selected parameter appears.
- ② Press the [▲] or [▼] button to adjust the setting, and press the ok button.
 - The selected parameter is set, and you are returned to the Printer Settings Menu.
 - Follow the same procedure to adjust the other parameters, as desired.
 - The contents of the settings that can be made for each parameter will differ depending on the printer.

<When “ VALUES” is selected>

- The images will be printed according to the settings specified on the printer side.

HINT

- The parameters that are displayed on the Printer Settings Menu will differ depending on the printer that is connected.
- To use printer functions which do not appear on your camera's Printer Settings Menu, select “ VALUES”.
- If a function set by the camera is not available in the printer, the camera's printer settings will automatically change to “ VALUES”.



COMMONLY ASKED QUESTIONS

If you have a question about the camera operation, you might find the answer in this compilation of commonly asked questions.

	Question	Answer	Action
Power	Why doesn't the power turn on?	Due to cold temperatures, the battery pack temporarily lost their power.	Place the camera in your pocket to warm it up before using it.
	Why is the battery pack consumed so quickly?	The ambient temperature is very low.	Keep the battery pack in an environment of 10 to 40°C (50 to 104°F).
		The battery pack life has expired.	Replace with a new battery pack.
Why does the  icon appear?	The remaining battery pack power is low.	Recharge the battery pack.	
Shooting	Why doesn't the flash operate?	The camera has determined that the image is bright enough and the flash is not necessary.	Not a malfunction. Capture the image; the camera will determine when the flash is necessary.

COMMONLY ASKED QUESTIONS

	Question	Answer	Action
Shooting	Are the settings retained even after the camera is turned off?	—	All settings except the self-timer and the exposure correction are retained even after the camera is turned off.
	Which resolution setting should I use?	—	Select the resolution setting according to the intended use: 7M 5M : Appropriate for printing letter-size or larger, and for printing a close-up of part of a photo (trimming). 3M : For printing standard photo (photo service) sizes. 1M 0.3M : For photos displayed on a web page, or sent as e-mail attachments.
	What is the difference between the digital zoom and the optical zoom?	—	Because shooting with the optical zoom uses the optics of a physical lens, you can shoot without losing minute details in the image. The digital zoom, on the other hand, works by magnifying a portion of the image that hits the CCD sensor and may produce a coarser image.

	Question	Answer	Action
Shooting	How can I get the distant view into focus?	—	Set focus range to infinity  or the scene function to the landscape  mode when photographing.
Monitor	When used in cold weather, why does the image seem to leave traces as it moves?	Condition due to the liquid crystals.	Not a malfunction. Spots that appear in the monitor only appear in the monitor and will not be recorded with the images.
	Why does the displayed image contain some red, blue and green dots, or why are black spots visible?		

COMMONLY ASKED QUESTIONS

	Question	Answer	Action
Viewing images	Why is the image too bright?	The subject was too bright.	When capturing an image, devise a way to compensate for a bright subject, for example, by changing the shooting angle.
	Why is the image out of focus?	The focus is not locked properly.	Hold the camera correctly, and when the image is locked in focus, gently press the shutter button all the way to capture the image.
	Why is there no image (□ is shown)?	This may happen when trying to play back images stored on a card from a different digital camera.	Play back images that were recorded on a card using this camera.
	Why do vertical stripes appear?	If a bright subject is shot in the video clip recording mode, vertical stripes may appear on the monitor or in the image.	Not a malfunction.

	Question	Answer	Action
Viewing images	Why isn't the magnified image clear?	Due to the characteristics of the camera, magnified images appear less clear.	Not a malfunction.
	Why isn't the captured image clear?	The image was captured using the digital zoom.	Not a malfunction. Zoom in only within the optical zoom range when shooting.
	Can I play back image data that I edited using my computer?	—	We cannot guarantee the accurate playback of data that has been edited using a computer.
Printing	Why does a message appear during PictBridge printing?	There is a problem with the printer.	Please refer to the instruction manual for your printer.
Misc.	Why does the "Card full" or "Internal memory full" message appear?	There is no more available memory on the card or in the camera's internal memory.	Erase unnecessary data, or use a card that has more memory available.
	Why does the "Card is protected" message appear?	The lock switch on the card is in the locked (protect) position.	Move the lock switch to the unlocked position.

COMMONLY ASKED QUESTIONS

	Question	Answer	Action
Misc.	Why can't the camera be operated?	A temporary internal circuitry problem may be the cause.	Remove the battery pack from the camera, wait a few minutes, then reinstall the battery pack and try again.
	Can I use my camera abroad?	—	Yes. The battery charger is rated for 100V to 240V and can also be used abroad. You should purchase the necessary power outlet plug adaptors for the countries in which the battery charger will be used. Please note that product support may not be available abroad.
	Why does the "System error" message appear?	A problem has occurred within the camera or card.	Check the following items: ① Remove the card and then install it again. ② Remove the battery pack and then install them again. ③ Install a different card. If "System error" still appears after performing the above steps, then please contact Uniden customer support.

TROUBLESHOOTING

Before taking your camera to the repair shop, check the following table for a possible solution to the problem.

CAMERA

	Problem	Cause	Action	Reference page
Power	No power.	The battery pack is dead.	Recharge the battery pack.	13
		The battery pack has not been inserted correctly.	Reinsert the battery pack, making sure to orient them correctly.	16
	The camera turns off by itself.	The power save function is operating.	Not a malfunction.	19
Shooting	An image is not captured when the shutter button is pressed.	The power is not turned on.	Press the on/off button to turn the camera on before taking pictures.	18

TROUBLESHOOTING

	Problem	Cause	Action	Reference page
Shooting	An image is not captured when the shutter button is pressed.	The maximum number of images that can be captured or the maximum video clip recording time has been reached.	Install a new card.	16
			Erase the images that are not necessary. Save the images to separate media, then erase all the images from the card.	35, 91
	The flash does not operate.	The flash off mode is selected.	Set the flash to automatic flash mode or forced flash mode.	47
		The battery pack is dead.	Recharge the battery pack.	13
	The "Battery depleted" message appears.	The battery pack is consumed.	Recharge the battery pack.	13

	Problem	Cause	Action	Reference page
Shooting	When zooming in or out, the zoom movement stops momentarily.	The optical zoom has moved to the maximum magnification position.	Not a malfunction. Release the zoom switch, and press it again.	46
	There is noise in the captured image.	The ISO sensitivity setting is too high.	Set the ISO sensitivity to a lower setting.	60
Monitor	No playback image appears.	The playback mode is not active.	Press the playback button [▶].	26
Viewing images	The image is too dark.	The flash was blocked by a finger or other object.	Hold the camera correctly, and make sure the flash is not obstructed.	23
		The subject was too far away.	Capture the image in the range of operation of the flash.	128

















TROUBLESHOOTING

	Problem	Cause	Action	Reference page
Viewing images	The image is too dark.	The subject was lit from behind.	Use the forced flash mode.	47
			Use the exposure correction function.	62
		There is not enough light.	Adjust the ISO sensitivity setting.	60
	The image is too bright.	The forced flash mode is selected.	Select a different flash mode.	47
		The subject was too bright.	Use the exposure correction function.	62
		The ISO sensitivity setting is incorrect.	Set the ISO sensitivity to [ISO-A] .	60
	The image is not in focus.	The subject is too close to the camera.	Select the correct focus setting for your needs.	30, 51
		The focus setting is not correct.		
		The camera moved when the shutter button was pressed.	Hold the camera correctly and press the shutter button correctly.	23, 30
		The focus is not locked properly.		
		The lens is dirty.	Clean the lens.	—

	Problem	Cause	Action	Reference page
Viewing images	The colors of the images captured indoors are not correct.	This is due to ambient lighting.	Capture the image using the forced flash mode.	47
		The white balance setting is incorrect.	Set the white balance setting correctly.	61
	A part of the image is missing.	The handstrap or a finger was blocking the lens.	Hold the camera correctly, and make sure the lens is not obstructed.	23
	“No image” is shown.	There is no image stored in the installed card or the internal memory.	Play back after capturing images.	30, 32
Image editing	You cannot edit or rotate an image.	The protect mode is set.	Cancel the protect mode.	66
Misc.	The “Image is protected” message appears and the data cannot be erased.	You have attempted to erase data that is protected from accidental erasure.	Set the protect setting for the data to UNLOCK.	66
	The recording capacity is less than that indicated in the section “Possible Number of Images/Video Recording Time/Audio Recording Time”.	The recording capacity is less than the value specified for the card.	Depending on the card, the capacity may be less than the specified value. Please refer to the instructions that accompanied the card.	131

TROUBLESHOOTING

Notes regarding the scene function

	The macro  focus range setting is not available.
	
	The resolution cannot be set to 3M or more. The flash is disabled even when shooting single shots.
	The macro  focus range setting is not available.
	
	The macro  focus range setting is not available. The flash is disabled even when shooting single shots. The AF seeker  focus mode setting is not available.
	The distant  and pan PF focus range settings are not available.
	The pan PF , macro  and distant  focus range settings are not available. The AF seeker  focus mode setting is not available.



SPECIFICATIONS

Camera

Type	CCD digital camera (recording and playback)
Image file format	Still images: JPEG format (DCF, DPOF, Exif 2.2 compliant) Note: Designed mainly by the Japan Electronics and Information Technology Industries Association (JEITA), DCF (Design rule for camera file system) is standard for digital still camera image files to provide interoperability between digital photography devices for the images stored on removable memory cards. However, it is not guaranteed that all devices will support the DCF standard. Video clips: QuickTime Movie (Photo-JPEG) Audio recordings : WAVE format (monaural)
Data storage media	Internal memory: Approx. 23 MB External memory: SD Memory Card (equivalent to a 4 GB SDHC memory card), Multi Media Card
Camera effective number of pixels	Approx. 7.13 million pixels (7.13 megapixels)
Image sensor	1/2.5-inch (10.16 mm) CCD Virtual number of pixels: Approx. 7.41 million pixels (7.41 megapixels), interlace scan, primary color filter

SPECIFICATIONS

Recording resolution	<Still image shooting mode> 7M : 3,072 × 2,304 pixels 5M : 2,592 × 1,944 pixels 3M : 2,048 × 1,536 pixels 1M : 1,024 × 768 pixels 0.3M : 640 × 480 pixels <Video clip recording mode> TV : 640 × 480 pixels, 30 frames/second WEB : 320 × 240 pixels, 15 frames/second WGS : 160 × 120 pixels, 15 frames/second	
White balance	Full-auto TTL, manual setting possible	
Lens	3.0× optical zoom lens	f=6.3 mm to 18.9 mm (35 mm film camera conversion: 38 mm to 114 mm) Autofocus, 5 groups, 6 elements (6 with aspheric surfaces)
Aperture	Open F=3.1 (Wide) to 5.9 (Tele)	
Exposure control type	Programmable AE Exposure correction available from the Recording Menu (0±2.0 EV in 1/3 EV steps)	
Light-measuring modes	Multi-section measuring	

Range	Normal photography: 10 cm (3.94 in.) to ∞ (Wide), 60 cm (23.62 in.) to ∞ (Tele) Macro photography: 5 cm (1.97 in.) to 80 cm (31.50 in.) (Wide), 60 cm (23.62 in.) to 80 cm (31.50 in.) (Tele)
Digital zoom	For shooting: 1× to 4× For playback: 1× to 48× (varies with resolution)
Shutter speed	Single-shot mode: 1/2 to 1/2,000 sec. (Maximum approx. 2 seconds when the scene function is set to fireworks  etc.) (During flash: 1/30 to 1/2,000 sec.) Sequential shots mode: 1/2 to 1/2,000 sec. Video clip recording mode: 1/30 to 1/10,000 sec.
Sensitivity	Single-shot mode/sequential shots mode: Auto (equivalent to ISO50 to 400)/equivalent to ISO50, ISO100, ISO200, ISO400, and ISO800 (switchable from Recording Menu) Maximum sensitivity equivalent to ISO3,200 (when the scene function is set to ) Video clip recording mode: Equivalent to ISO200 to 800
Monitor	2.5-inch (6.35 cm) TFT color LCD Approx. 115,000 pixels (Frame coverage: Approx. 100%) Brightness adjustment: 5-step, auto

SPECIFICATIONS

Flash working range	GN = 6 Approx. 40 cm (15.75 in.) to 3.8 m (12.47 ft.) (Wide) Approx. 60 cm (23.62 in.) to 2.0 m (6.56 ft.) (Tele)	
Flash modes	Auto-flash, forced flash, flash off, red-eye reduction	
Focus	TTL-type AF (9-point range finder/spot focus/AF seeker)	
Self-timer	Approx. 2-second delay, 10-second delay	
Ambient environment	Temperature	0 to 40°C (32 to 104°F) (operation), -20 to 60°C (-4 to 140°F) (storage)
	Humidity	30 to 85% (operating, no condensation) 10 to 90% (storage, no condensation)
Power supply	Battery pack	Lithium-ion battery pack (BT-1003) × 1
Dimensions (at narrowest part, not including protrusions)	91.0 (W) × 55.5 (H) × 21.1 (D) mm 3.58" (W) × 2.19" (H) × 0.83" (D)	
Weight	Approx. 120 g (4.23 oz.) (without battery pack and card)	

Camera connectors

A/V OUT (communication/audio and video output) terminal	Dedicated regrouped jack	
	Audio output	880 mVrms (-1.1 dBs), 2.2 k Ω or less, monaural
	Video output	1.0 Vp-p, 75 Ω unbalanced, sync negative, composite video, NTSC color TV system/PAL TV system (switchable from the Option Menu)
	USB	USB 2.0 Full Speed
DC IN (external DC power input) terminal	DC 5 V (2A or more) EIAJ type 2 (The battery pack cannot be recharged while it is installed in the camera.)	

Battery life

Shooting	Still image shooting mode	300 images: CIPA standard (when a Matsushita 64 MB SD Memory Card is used)
	Video clip recording mode	120 minutes: Recorded in TV mode (640 \times 480 pixels, 30 fps)
Playback		500 minutes: Monitor on, continuous playback (BGM: OFF)

- Until battery pack runs out when using a fully charged battery pack at a 25°C (77°F) ambient temperature.
- The operation time may vary depending on the conditions of the battery pack and the conditions of use. Especially when used at temperatures below 10°C (50°F), the battery pack operation time is drastically reduced.

SPECIFICATIONS

Possible Number of Images/Video Recording Time/Audio Recording Time

The table shows the possible number of captured images and the possible recording time for the camera's internal memory and for the commercially available 512 MB and 4 GB SD Memory Cards.

Shooting mode setting	Resolution setting	Internal memory	SD Memory Card	
			512 MB	4 GB
Still image shooting mode	7M	10 images	213 images	1,700 images
	5M	14 images	297 images	2,380 images
	3M	23 images	476 images	3,760 images
	1M	115 images	2,380 images	9,990 images
	0.3M	299 images	6,180 images	9,990 images
Video clip recording mode	TV	22 sec.	7 min. 48 sec.	1 hr. 2 min.
	WEB	1 min. 14 sec.	25 min. 47 sec.	3 hr. 26 min.
	60S	4 min. 59 sec.	1 hr. 43 min.	11 hr. 29 min.
Audio file mode	—	49 min. 49 sec.	17 hr. 11 min.	99 hr. 59 min.

- Up to 5 hours of continuous recording in the 60S video clip recording mode.
- Up to 9 hours of continuous audio recording is possible.
- The values were determined using an SD Memory Card by Sandisk.
- Even with cards of the same capacity, the amount of data that can actually be stored may differ depending on the card brand, etc.
- The continuous shooting time for each video clip will differ depending, for example, on the card capacity, environmental conditions (temperature and shooting conditions, etc.).

Supplied battery pack charger

Part No.		RC3701
Power source		AC 100 to 240 V, 50 to 60 Hz, 10 VA
Rated output		DC 4.2 V, 650 mA
Compatible batteries		Supplied or separately sold Lithium-ion battery pack (BT-1003)
Ambient environment	Temperature	0 to 40°C (32 to 104°F) (recharge), -20 to 60°C (-4 to 140°F) (storage)
	Humidity	20 to 80% (no condensation)
Dimensions		46 (W) × 21.2 (H) × 91 (D) mm 1.81" (W) × 0.83" (H) × 3.58" (D)
Weight		Approx. 55 g (1.9 oz.) (not including power cord)
Power cord rated value	For North America	AC 125 V, 3 A
	For Australia	AC 250 V, 2.5 A

- When using the supplied battery pack charger abroad, the power cord may need to be replaced in accordance with local requirements. Please contact Uniden customer support.

Supplied Li-ion battery pack

Part No.		BT-1003
Voltage		3.7 V
Rated output		720 mAh
Ambient environment	Temperature	0 to 40°C (32 to 104°F) (during use, recharged) -10 to 30°C (14 to 86°F) (storage)
	Humidity	10 to 90% (no condensation)
Dimensions		39.4 (W) × 6.0 (H) × 35.5 (D) mm 1.55 (W) × 0.24 (H) × 1.40 (D) in.
Weight		Approx. 19 g (0.7 oz.)

SPECIFICATIONS

Others

Copyrights

- Apple, Macintosh and QuickTime are trademarks or registered trademarks of Apple Computer Inc.
- Microsoft and Windows are registered trademarks of Microsoft Corporation in the USA and other countries.
- SDHC is a trademark.



- All other company and product names are registered trademarks or trademarks of their respective owners.

CAUTION

- It is forbidden to copy this manual, whole or in part, without prior written permission.
- All images and illustrations given in this manual are for explanation purposes and may differ slightly from that of the actual product. Also, actual specifications are subject to change without prior notice and therefore may differ from the contents of this manual.
- Uniden Corporation shall not be held responsible for any problems resulting from the use of this camera.
- Uniden Corporation declines all responsibility for damages due to improper use of the camera, failure to adhere to the instructions given in this manual, or repairs or changes done by those other than a technician authorized by the manufacturer.
- Uniden Corporation shall not be held responsible for any damage caused by optional devices or consumable items used with the camera other than those supplied with the camera or those specified by Uniden Corporation.
- Uniden Corporation shall not be held responsible for any losses or loss of revenue resulting from the loss of data caused by the malfunction, or the repairing of a malfunction, of the camera.
- The images captured with this camera will differ in quality from pictures taken with a standard film camera.

Uniden®