

# Uniden®

## XDECT 8015 Series

---

*For more exciting new products please visit our website:*

*Australia: [www.uniden.com.au](http://www.uniden.com.au)*

*New Zealand: [www.uniden.co.nz](http://www.uniden.co.nz)*

---

# OWNER'S MANUAL

# Important Safety Instructions!

When using your telephone equipment, basic safety precautions should always be followed to reduce the risk of fire, electric shock and injury to persons, including the following:

- ◆ **This unit is NOT waterproof.** DO NOT expose this unit to rain or moisture.
- ◆ Do not use this product near water, for example, near a bath tub, wash bowl, kitchen sink or laundry tub, in a wet basement or near a swimming pool.
- ◆ Avoid using a telephone (other than a cordless type) during an electrical storm. There may be a remote risk of electric shock from lightning.
- ◆ Do not use the telephone to report a gas leak in the vicinity of the leak.
- ◆ Use only the power cord and batteries indicated in this manual. Do not dispose of batteries in a fire. They may explode. Check with local codes for possible special disposal instructions.
- ◆ Do not place the handset in any charging cradle without the battery installed and the battery cover securely in place.

---

***SAVE THESE INSTRUCTIONS!***

---

## **Important Notice:**

- ◆ Under power failure conditions this appliance may not operate. Please ensure that a separate telephone, not dependent on local power, is available for emergency use.

## **General Notices for New Zealand Model:**

- ◆ The grant of a NZ Telepermit for any item of terminal equipment indicates only that Telecom has accepted that the item complies with minimum conditions for connection to its network. It indicates no endorsement of the product by Telecom, nor does it provide any sort of warranty. Above all, it provides no assurance that any item will work correctly in all respects with another item of Telepermitted equipment of a different make or model, nor does it imply that any product is compatible with all of Telecom's network services.
- ◆ The maximum volume setting of this telephone exceeds the Telecom specified volume requirement. Telecom takes no responsibility for the high volume available on this telephone, customer's who believe this telephone is too loud should contact the manufacturer at the website indicated on owner's manual warranty page.
- ◆ For telephone networks other than Telecom there may be a charge incurred for local calls if the Insert 0 feature is on. Turn Insert 0 off.
- ◆ This equipment may not provide for the effective hand-over of a call to another device connected to the same line.

# XDECT 8015 Series

## What's in the box?

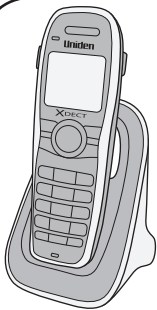

XDECT 8015  
base & cordless  
handset

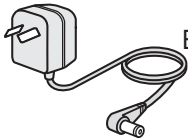

Base AC adapter  
(PS-S0635YL3)

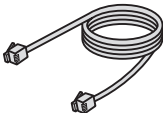

Telephone  
cord

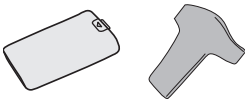

Battery  
cover &  
Belt clip

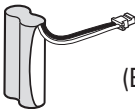

Rechargeable  
battery pack  
(BT-694 or BT-694s)



HS915  
Headset

- ◆ If any items are missing or damaged, contact your place of purchase immediately.  
Never use damaged products!
- ◆ Need Help? Get answers at our website:  
[www.uniden.com.au](http://www.uniden.com.au) for Australian model  
[www.uniden.co.nz](http://www.uniden.co.nz) for New Zealand model.

## You might also find:



XDECT 8005  
accessory  
handset &  
charger

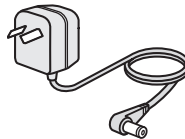

Charger AC  
adapter  
AAD-600S(M)

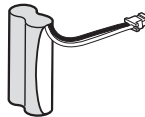

Rechargeable  
battery pack  
(BT-694 or BT-694s)

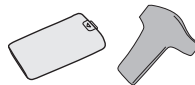

Battery  
cover &  
Belt clip

If you purchased model number:	You should have:
XDECT 8015	None
XDECT 8015+1	1 of each
XDECT 8015+2	2 of each
XDECT 8015+3	3 of each

# Contents

Features of the XDECT 8015 Series .....	5
<b>INSTALLING YOUR PHONE</b> .....	<b>6</b>
Charge the Battery .....	6
Connect the Telephone Cord / <i>Test the Connection</i> / Installing the Belt Clip .....	7
Headset Installation .....	8
Mounting the base unit on a wall .....	8
<b>GETTING TO KNOW YOUR PHONE</b> .....	<b>9</b>
Parts of the Base & Handset .....	9
Reading the Handset Display .....	11
<b>USING THE HANDSET MENUS</b> .....	<b>12</b>
<i>Handset Setup</i> .....	13
<i>Date &amp; Time</i> .....	14
<i>Global Setup</i> .....	14
Entering Text on Your Phone .....	15
<b>USING YOUR PHONE</b> .....	<b>16</b>
Changing the Volume .....	16
Using the Redial List .....	17
Using Caller ID and Call Waiting .....	17
<i>Dialling from the Caller ID list</i> .....	17
<i>Caller ID menu options</i> .....	18
Using the Phonebook .....	19
<i>Phonebook menu options / Phonebook entry options</i> .....	19
Chain Dialing .....	20
Finding a Lost Handset .....	20
<b>USING SPECIAL FEATURES</b> .....	<b>21</b>
Using Voice Message Notification .....	21
<i>Setting Up Your Voice Mail / Getting Your Messages</i> .....	21
<i>Resetting the voice message indicator</i> .....	21
<b>USING MULTI-HANDSET FEATURES</b> .....	<b>22</b>
Expanding Your Phone .....	22
Using Conference Calling .....	22
Using Privacy Mode .....	23
Using Call Transfer .....	23
Using the Intercom .....	24
Do Not Disturb (DND) .....	24
<b>SOLVING PROBLEMS</b> .....	<b>25</b>
Weak or Hard To Hear Audio .....	26
Noise or Static On The Line .....	26
<i>Here are some hints for when the static is</i> .....	27
<i>Inserting a line filter or DSL filter</i> .....	27
Resetting and Registering Handsets .....	28
<i>Registering a handset</i> .....	28
Handling Liquid Damage .....	29
<b>IMPORTANT INFORMATION</b> .....	<b>30</b>
Terms Used In This Guide .....	30
Specifications .....	31
Automatic ECO (Power Save) Mode .....	31
Battery Information .....	32
<b>INDEX</b> .....	<b>33</b>
<b>ONE-YEAR LIMITED WARRANTY</b> .....	<b>34</b>

## Features of the XDECT 8015 Series

### Great features of this cordless phone include:

- ◆ Designed and Engineered in Japan
- ◆ 1.8GHz Extended DECT Technology
- ◆ Multi (12) Handset Capable<sup>1</sup>
- ◆ Multi (2) Repeater Capable (optional)
- ◆ Wall Mountable Base
- ◆ Extra Large Backlit LCD Display with Date & Time
- ◆ Backlit Keypad
- ◆ Digital Duplex Speakerphones on Handset
- ◆ 100 Number Phonebook (shared)
- ◆ Call Waiting<sup>2</sup>/Flash
- ◆ Caller ID<sup>2</sup> Features
  - ◆ 50 Caller ID<sup>2</sup> Memories (shared)
  - ◆ Caller Name Tag<sup>2</sup>
  - ◆ Caller Personal Ring<sup>2</sup>
- ◆ 9 Ringer options (4 Rings/5 Melodies)
- ◆ 4 Level Ringer Volume
- ◆ Ringer Do Not Disturb (DND) mode
- ◆ 6 Level Earpiece Volume
- ◆ 6 Level Speaker Volume
- ◆ 5 Number Redial Memories
- ◆ Intercom/Announce Call Transfer
- ◆ up to 7 Days Standby Time
- ◆ up to 10 Hours Talk Time
- ◆ Automatic ECO (power save) Mode
- ◆ Mute/Hold
- ◆ Headset Capable
- ◆ Beltclip
- ◆ And More!

<sup>1</sup> Maximum expandable with XDECT 8005 accessory handsets. Note: Expansion capacity is limited to six (6) handsets total if an XDECT 8015WP or XDECT 8005WP (waterproof) handset is registered.

<sup>2</sup> Caller ID, Call Waiting features work only if you subscribe to the service provided by your local telephone company. There is usually a fee for this service. Name Tag and Personal Ring features require incoming Caller ID data.

Specifications subject to change. Visit the XDECT 8015 webpage on the website for the latest information.

# Installing Your Phone

## Charge the Battery

- 1) Unpack all handsets, battery packs, and battery covers. If any battery cover is already on the handset, press in on the notch and slide the cover down and off.

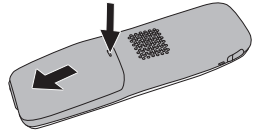

- 2) Line up the red and black wires on the battery pack with the label inside the handset.
- 3) Push the connector in until it clicks into place; tug gently on the wires to make sure the battery pack is securely connected.

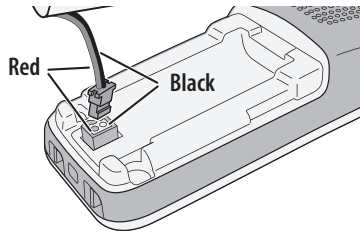

- 4) Place the cover over the battery compartment and slide it up into place.

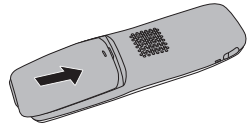

- 5) Connect the base AC adapter to the **DC IN 6V** jack on the rear of the base. Route the cord through the molded wiring channel as shown.

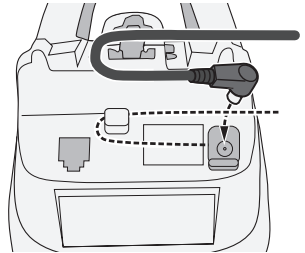

- 6) If you have accessory handsets, connect a charger AC adapter to each charger's **DC IN 9V** jack and set the plug into the notch as shown.

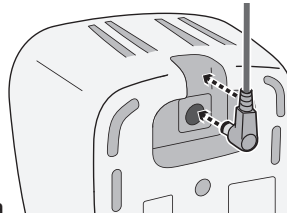

- 7) Plug the other end of each adapter into a standard 240V AC power outlet.

- 8) Place a handset in the base and any accessory handset(s) in the charger(s) with the display(s) facing forward. The **CHARGE** light on the handset(s) should turn on.



If...	Try...
the <b>CHARGE</b> light does not turn on	<ul style="list-style-type: none"> <li>- reseating the handset.</li> <li>- checking the AC adapter connection.</li> <li>- seeing if the outlet is controlled by a wall switch.</li> </ul>

**Charge all handsets completely (about 15 hours) before using them.**

### Connect the Telephone Cord

Use the telephone cord to connect the **TEL LINE** jack to a standard telephone wall jack.

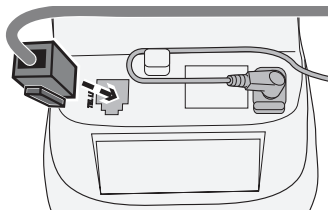

### Test the connection

- 1) Pick up the handset from the cradle and press **TALK/FLASH**. You should hear a dial tone, and the display should say *Talk*.

If...	Try...
you don't hear a dial tone or the display says <i>Check Tel Line</i>	checking the connection between the base and the phone jack.

- 2) Make a quick test call. (Press **END** to hang up.)

If...	Try...
there's a lot of noise or static	see page 26 for tips on avoiding interference.

- 3) Test any accessory handsets the same way. If you can't get a dial tone or the handset display says *Unavailable*, try moving the handset closer to the base or resetting it (see page 28). Charge all handsets completely (about 15 hours) before using them.

### Installing the Belt Clip

Line up the holes on each side of the handset. **To attach the belt clip**, insert into the holes on each side of the handset. Press down until it clicks. **To remove the belt clip**, pull either side of the belt clip to release the tabs from the holes.

## Headset Installation

Your phone may be used with the Uniden HS915 headset. **To use this feature**, insert the headset plug into the headset jack. Your phone is ready for hands-free conversations. Additional headsets are available through Uniden authorized retailers.

## Mounting the base unit on a wall

You can mount your base directly to the wall. Before doing this, consider the following:

- Avoid electrical cables, pipes, or other items behind the mounting location that could cause a hazard when inserting screws into the wall.
  - Mount your phone within distance of a working phone jack.
  - Make sure the wall material is capable of supporting the weight of the base and handset.
  - Use screws with anchoring devices suitable for the wall material where the base unit will be placed.
- 1) Insert two mounting screws into the wall (with their appropriate anchoring device), 85mm apart. Allow about 3mm between the wall and screwheads for mounting the phone.
  - 2) Plug the AC adapter into the **DC IN 6V** jack on the telephone and then into a Standard AC wall outlet.
  - 3) Plug the telephone cord into the **TEL LINE** jack on the telephone and then into the telephone socket on the wall.
  - 4) Align the mounting slots on the base with the mounting posts on the wall.
  - 5) Then push in and down until the phone is firmly seated.

This phone also can be mounted on any standard telephone wall plate (for Australia).

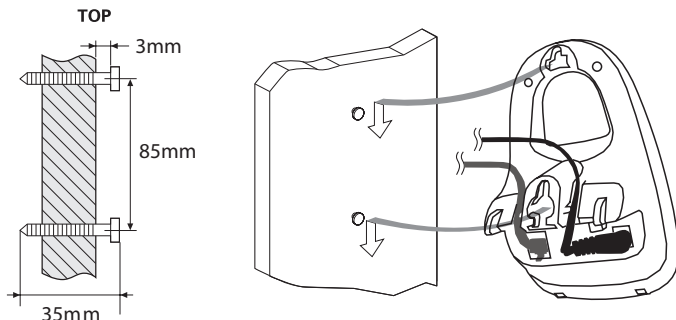

# Getting to Know Your Phone

## Parts of the Base & Handset

If the key name is spelled out on the key itself, it's not labeled in the drawings.



*Base keys and how they work*

Key name	What it does
<b>FIND</b>	- In standby: page all handsets so you can find a lost one.
<b>CHARGING CONTACTS</b>	- Charge contacts with handset locator.

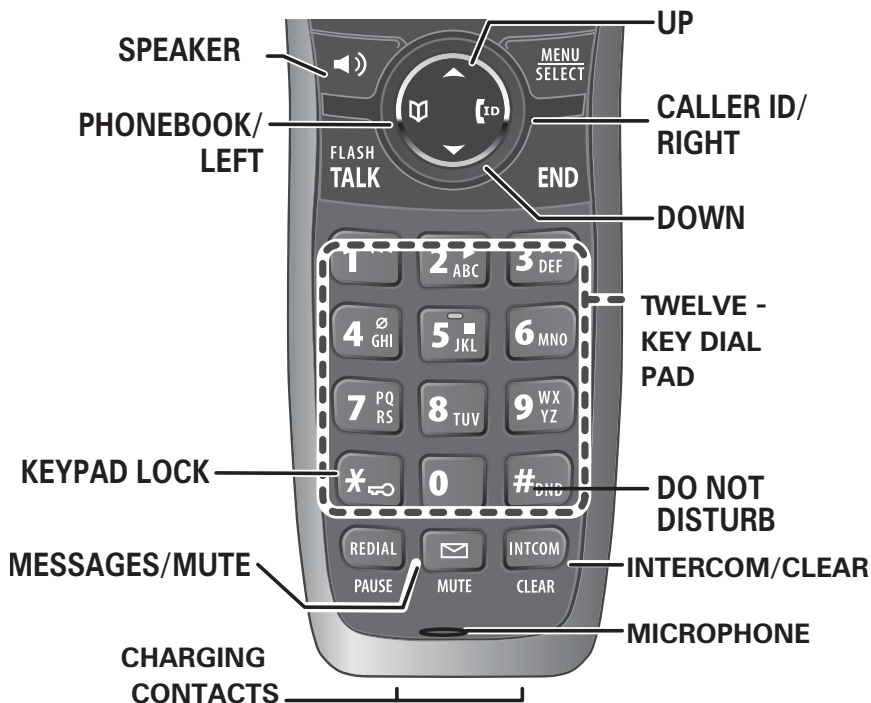

## Handset keys and how they work

Key name (and icon)	What it does
<b>UP (▲)</b>	<ul style="list-style-type: none"><li>- In standby: increase the ringer volume.</li><li>- During a call: increase the call volume.</li><li>- In the menu or any list: move the cursor up one line.</li></ul>
<b>CALLER ID/ RIGHT (ID)</b>	<ul style="list-style-type: none"><li>- In standby or during a call: open the Caller ID list.</li><li>- During text entry: move the cursor to the right.</li></ul>
<b>DOWN (▼)</b>	<ul style="list-style-type: none"><li>- In standby: decrease the ringer volume.</li><li>- During a call: decrease the call volume.</li><li>- In the menu or any list: move the cursor down one line.</li></ul>
<b>MENU/SELECT</b>	<ul style="list-style-type: none"><li>- In standby: open the menu.</li><li>- In the menu or any list: select the highlighted item.</li></ul>
<b>END</b>	<ul style="list-style-type: none"><li>- During a call: hang up.</li><li>- In the menu or any list: exit &amp; go to standby.</li></ul>
<b>INTERCOM/ CLEAR</b>	<ul style="list-style-type: none"><li>- In standby: page another handset using the intercom.</li><li>- During a call: put the call on hold &amp; start a call transfer.</li><li>- While entering text: delete one character, or press &amp; hold to delete all the characters.</li></ul>
<b>PHONEBOOK/ LEFT (M)</b>	<ul style="list-style-type: none"><li>- In standby or during a call: open the phonebook.</li><li>- In the menu: go back to the previous screen.</li><li>- During text entry: move the cursor to the left.</li></ul>
<b>#/DND</b>	<ul style="list-style-type: none"><li>- Do Not Disturb - Opens a menu to disable the ringer on all handsets for a set time period.</li></ul>
<b>*/ LOCK</b>	<ul style="list-style-type: none"><li>- In standby: press and hold to lock or unlock the keypad.</li></ul>
<b>TALK/FLASH</b>	<ul style="list-style-type: none"><li>- In standby: start a telephone call (get a dial tone).</li><li>- During a call: switch to a waiting call.</li></ul>
<b>SPEAKER (◀▶)</b>	<ul style="list-style-type: none"><li>- Switch a normal call to the speakerphone (&amp; back).</li></ul>
<b>REDIAL/PAUSE</b>	<ul style="list-style-type: none"><li>- In standby: open the redial list.</li><li>- While entering a phone number: insert a 2-second pause.</li></ul>
<b>MESSAGE (✉) /MUTE</b>	<ul style="list-style-type: none"><li>- In standby: access your voice mail (see page 21).</li><li>- During a call: mute the microphone.</li><li>- While the phone is ringing: mute the ringer for this call only.</li></ul>

## Reading the Handset Display

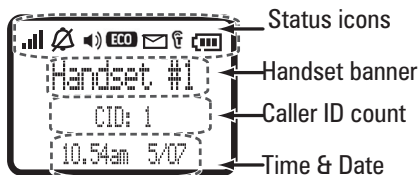

The table below shows the possible icons and what they mean. Since the icons appear based on what you're doing with the phone, you won't ever see all of these icons at the same time.

Icon	What it means
	Received signal strength indicator.
	The ringer is turned off: this handset will not ring when a call comes in.
	You have a voice message waiting (see the section titled "Using Voice Message Notification" on page 21).
	Privacy Mode is on: no other handset can join your call.
	The speakerphone is on.
	The handset is using ECO (power save) mode. The ECO feature is automatically activated during talk or intercom modes. See "Automatic ECO (Power Save) Mode" on page 31).
	T-coil mode is on. (See "Do you use a T-coil hearing aid?" on page 26.)
	The battery levels; Level 3 (Full) Level 2 Level 1 Level 0 (Empty)

## Using the Handset Menus

The menus are designed to be as easy as possible. Some users don't even need the manual once they know how to perform these actions:

To...	Press...
Open the menu	Press <b>MENU/SELECT</b> .
Highlighting menu options	Use <b>UP</b> to highlighted option above & <b>DOWN</b> to highlight the option below.
Select an option	Move the cursor to highlight the option, then press <b>MENU/SELECT</b> .
Go up one screen	Press <b>PHONEBOOK/LEFT</b> .
Close the menu	Press <b>END</b> . (If you open the menu during a call, use <b>PHONEBOOK/LEFT</b> to back out of the menu without hanging up.)

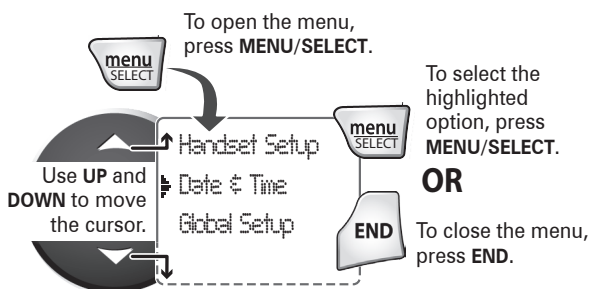

**If you don't press any keys for thirty seconds, the phone times out and exits the menu. (When setting the date and time, the time-out period is extended to two minutes.)**

## Handset Setup

You can change these settings separately for each handset.

<i>Menu Option</i>	<b>What it does</b>
<i>T-coil</i>	Turn on T-coil mode to reduce noise on some hearing aids (see "Do you use a T-coil hearing aid?" on page 26).
<i>Ringer Tones</i>	Choose one of four ringers and five melodies for the handset's main ring tone. As you highlight each ring tone, the phone plays a sample of the tone. When you hear the tone you want, press <b>MENU/SELECT</b> .
<i>Personal Ring</i>	Turn on the personal ring feature. If you have Caller ID, this feature lets you assign special ring tones to anyone in your phonebook: this handset will use the special ring tone when that person calls.
<i>Autotalk</i>	Turn on Auto Talk so you can answer the phone just by picking up the handset from the cradle (without having to press any buttons).
<i>Any Key Answer</i>	Turn on Any Key Answer so you can answer the phone by pressing a key on the twelve-key dial pad.
<i>Banner</i>	Change the name used on the handset's display.
<i>Key Touch Tone</i>	Have the keypad sound a tone when you press a key.
<i>LCD Contrast</i>	Choose from ten LCD contrast levels.

## **Date & Time**

If you set the date & time, the clock in your handset's display will be correct. The date & time format is;  
day/month/year, hour/minutes/am/pm

- 1) Use the number keypad (**0-9**) or **UP/DOWN/LEFT/RIGHT** to enter the day of the month, year and then hour, minutes and AM or PM.
- 2) Press **MENU/SELECT** to confirm.

## **Global Setup**

The settings on this menu apply to all handsets and the base. Before changing these settings, make sure the phone is in standby and all handsets are within range of the base. (Only one handset at a time can change these settings.)

<i>Menu Option</i>	<b>What it does</b>
<i>Set Line Mode</i>	Do not change this setting unless instructed to by customer service.
<i>VMWI Reset</i>	Resets the Voice Mail Waiting Indicator LED.
<i>Edit Voice Mail</i>	If you subscribe to a Voice Mail service you can set the Voice Mail number .
<i>Insert 0</i>	This feature adds "0" or "00" at the beginning of the number received from Caller ID. The default setting for New Zealand is ON. The default setting for Australia is OFF.

## Entering Text on Your Phone

When you want to enter text into your phone (for example, a name in the phonebook), use the twelve-key dial pad to enter the letters printed on the number keys. Here's how it works:

- ◆ The phone enters the letters in the order they appear on the key. For example, if you press the number key **2** once, the phone enters the letter *A*. Press **2** twice for *B*, and three times for *C*.
- ◆ If you press the key again after the last letter, the phone starts the same letter sequence with small letters. If you press **2** four times in a row, the phone enters *a* (small letter). Press **2** five times for *b*, and six times for *c*.
- ◆ If you see the icon *[Aa]* in the display, the phone enters capital letters first (*A B C*), then small letters (*a b c*), then the number on the key (**2**). The icon *[aA]* means the phone starts at the small letters, so it enters small letters first, then the number on the key, then capital letters.
- ◆ The phone automatically uses a capital letter for the first letter and any letter right after a space; all other times, it uses small letters.
- ◆ If two letters in a row use the same number key, enter the first letter, then use **CALLER ID/RIGHT** to move the cursor to the next position to enter the second letter.

To	Follow these steps
Switch between capital & small letters	Press <b>* / 🔒 LOCK</b> .
Move the cursor	Press <b>PHONEBOOK/LEFT</b> to move the cursor to the left or <b>CALLER ID/RIGHT</b> to move the cursor to the right.
Leave a blank space	Press <b>#/DND</b> .
Erase one letter	Move the cursor to the letter you want to erase and press <b>INTCOM/CLEAR</b> .
Erase the entire entry	Press & hold <b>INTCOM/CLEAR</b> .
Enter punctuation or a symbol	Press <b>0</b> to rotate through the available symbols.

## Using Your Phone

To...	From a handset	From a handset speakerphone
make a call: Dial the number, then	Press <b>TALK/FLASH</b> .	Press <b>SPEAKER</b> .
answer a call	Press <b>TALK /FLASH</b> .	Press <b>SPEAKER</b> .
hang up	Press <b>END</b> or put the handset in the cradle.	
switch between the speaker & earpiece	Press <b>SPEAKER</b> .	Press <b>SPEAKER</b> .
mute the microphone during a call	Press <b>MESSAGE (✉) /MUTE</b> . Press again to turn the microphone back on.	
put a call on hold	Press <b>INTCOM/CLEAR</b> . If the call is on hold for 5 minutes, it will be disconnected.	
return to a call on hold	Press <b>TALK /FLASH</b> .	Press <b>SPEAKER</b> .
mute the ringer for this call only	While the phone is ringing, press <b>MESSAGE (✉) / MUTE</b> .	

## Changing the Volume

You can set the ringer, earpiece, and speaker volume separately for each handset. For each item, press **UP** to make it louder or **DOWN** to make it softer. The available volume levels and how change them are listed below:

Change the	When	On a handset
ringer volume	the phone is in standby	choose one of 4 volume levels. Note: lowest level is ringer off - and the ringer off icon shows on the display. See also - Do Not Disturb (DND) on page 24.
earpiece volume	you are on a normal call	choose one of 6 volume levels
speaker volume	you use the speaker-phone for a call.	choose one of 6 volume levels

## Using the Redial List

The phone saves the last 5 numbers you dial on each handset. To open the redial list, press **REDIAL/PAUSE**; use **UP** and **DOWN** to scroll through the list. To close the list, press **PHONEBOOK/LEFT**. With the phone in standby, open the list and find the number you want. Then:

To...	Press...
redial the selected number	Press <b>TALK/FLASH</b> or <b>SPEAKER</b> .
delete the number	Press <b>MENU/SELECT</b> & select <i>Delete</i> .
save it to the phonebook	Press <b>MENU/SELECT</b> & select <i>Store Into PH BK</i> .
delete all	Press <b>MENU/SELECT</b> & select <i>Delete All</i> .

## Using Caller ID and Call Waiting

You have to subscribe to **Caller ID**, **Call Waiting**, and **Caller ID on Call Waiting** services to use the features described in this section: contact your telephone provider for more information.

When a call comes in, the phone displays the caller's number and name (if available). The phone saves the information for the last 50 received calls to the *CID list*. When it's in standby, the phone displays how many calls came in since the last time you checked the CID list.

**All handsets share the same CID list so only one handset can access the list at a time.**

To...	Press...
Open the CID list	Press <b>CALLER ID/RIGHT</b> .
Scroll through the CID list	Press <b>DOWN</b> to scroll through the list from newest to oldest. Press <b>UP</b> to scroll from oldest to newest.
Close the CID list	Press <b>PHONEBOOK/LEFT</b> .

### ***Dialing from the Caller ID list***

- 1) Find the entry you want to dial.
- 2) Press **TALK /FLASH** or **SPEAKER** to dial the number.

(You can also press **TALK/FLASH** or **SPEAKER** before you open the CID list. Find the number you want to dial, then press **MENU/SELECT**.)

## Caller ID menu options

Open the CID list with the phone in standby. Find the number you want and press **MENU/SELECT**. Choose one of these CID menu options:

<i>Menu Option</i>	<b>What it does</b>
<i>Delete</i>	Erase this Caller ID number.
<i>Store Into PH BK</i>	Add this number to the phonebook. The phone prompts you to enter the name, edit the phone number, and choose a personal ring.
<i>Delete All</i>	Erase the CID list.

## Using Call Waiting

If you get a Call Waiting call, the phone sounds a tone and displays any CID information received for the waiting call.

### For Australian Model:

Press **TALK /FLASH** and then **2** on the handset to accept the waiting call. The first caller is put on hold, and you will hear the new caller after a short pause. To return to the original caller, press **TALK /FLASH** and then **2** again.

### For New Zealand Model:

Press **TALK /FLASH** on the handset to accept the waiting call. The first caller is put on hold, and you will hear the new caller after a short pause. To return to the original caller, press **TALK/FLASH** again.

**Note: You must subscribe to Call Waiting service for this feature to operate. Not all features are available in all areas.**

## Using the Phonebook

The phone can store up to 100 entries in its phonebook. All handsets share the same phonebook, so only one handset can access it at a time.

To...	Press...
Open/close the phonebook	Press <b>PHONEBOOK</b> .
Scroll through the entries	Press <b>DOWN</b> to scroll through the phonebook from A to Z or <b>UP</b> to scroll from Z to A.
Jump to entries that start with a certain letter	Press the number key corresponding to the letter you want to jump to.
Dial an entry	1. Find the entry you want to dial. 2. Press <b>TALK /FLASH</b> or <b>SPEAKER</b> .

### **Phonebook menu options**

Open the phonebook with the phone in standby, then press **MENU/SELECT** to open the phonebook menu. Choose one of these options:

<i>Menu Option</i>	<b>What it does</b>
<i>Create New</i>	Add an entry to your phonebook. The phone prompts you to enter the name and phone number, and choose a personal ring.
<i>Delete All</i>	Erase all the entries in this handset's phonebook.

### **Phonebook entry options**

With the phone in standby, open the phonebook and find the entry you want. Press **MENU/SELECT** to open the individual phonebook entry menu. Choose one of these options:

<i>Menu Option</i>	<b>What it does</b>
<i>Edit</i>	Edit this entry. The phone prompts you to edit the name and phone number, and choose a personal ring.
<i>Delete</i>	Erase this entry.

## Chain Dialing

- ◆ If you often have to enter a series of digits or a code number during a call, you can save that code number to a phonebook entry and use the phonebook to send the code number.
- ◆ Enter the code number (up to 20 digits) into the phonebook just like a regular phonebook entry. Be sure to enter the code number into the phonebook exactly as you would enter it during a call.
- ◆ When you hear the prompt that tells you to enter the number, open the phonebook and find the entry that contains your code number. Press **MENU/SELECT** to transmit the code. Or, if you change your mind, use **PHONEBOOK/LEFT** to close the phonebook.

## Finding a Lost Handset

With the phone in standby, press **FIND** on the base. All the handsets will beep for 1 minute, or until you press **FIND** again or any key on the handset.

# Using Special Features

## Using Voice Message Notification

This feature supports **Frequency-Shift Keying (FSK) message notification**. Contact your voice mail provider for more details.

If you subscribe to a voice mail service, your phone can notify you when you have a new message waiting. When you have new messages, the voice message icon (✉) appears in the display, and the new message light (at the top of the handset) blinks.



### Setting Up Your Voice Mail

When you sign up for a voice mail service, your service provider should give you an *access number*. If you don't have this information, contact your provider before you start.

- 1) With the phone in standby, open the menu.
- 2) Select *Global Setup*, then select *Edit Voice Mail*. For the New Zealand model the Telecom access number (083210) is pre-programmed.
- 3) Enter your access number exactly as you would dial it. You can enter a total of 20 digits. If you need the phone to wait for a few seconds between digits (to wait for the service to answer, for example), press **REDIAL/PAUSE** to insert a 2-second pause. If two seconds isn't long enough, you can insert as many pauses as you need, but each pause counts as one digit. Press **SELECT/MENU** when you're finished.

### Getting Your Messages

Press **MESSAGES** (✉)/**MUTE** and then **MENU/SELECT** to dial the access number you programmed into this handset.

### Resetting the voice message indicator

If the voice message icon remains after you check your messages, you can reset it.

- 1) With the phone in standby, open the menu.
- 2) Select *Global Setup*, then select *VMWI Reset*.
- 3) Select *Yes*.

## Using Multi-Handset Features

The expandable base works together with the accessory handsets to give you some useful multi-handset features. You must have at least two handsets to use the features in this section.

### Expanding Your Phone

- ◆ Your base supports a maximum of 12 cordless handsets: the one that came with the base and up to 11 XDECT 8005 accessory handsets.
- ◆ Note: Expansion capacity is limited to six (6) handsets total if an XDECT 8015WP or XDECT 8005WP (waterproof) handset is registered.
- ◆ Your base also supports a total of 2 repeaters, including any that came with your phone. Visit the XDECT 8055 page on the website for compatible repeaters.
- ◆ Your base might be compatible with other Uniden accessory handsets: please visit our website for a list of compatible handsets.
- ◆ Accessory handsets must be registered to the base before you can use them. Handsets that aren't registered display a *Handset not registered* message. For instructions on registering handsets to this base, see page 28 or refer to your accessory handset manual. Any accessory handsets that came packaged with the base are already registered to that base for you.
- ◆ If a handset was previously registered to a base, you have to reset it so you can register it to a new base (see page 28).

### Using Conference Calling

When an outside call comes in, two handsets can join in a conference call with the outside caller. To join the call, just press **TALK /FLASH**. To leave the conference call, hang up normally; the other handset remains connected to the call. (You can also use the handset speakerphone for a conference call, just like you can with a normal call.)

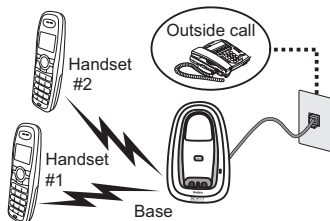

## Using Privacy Mode

You can prevent other handsets from joining a call. Start your call as usual, then press **MENU/SELECT**: the display shows *Call Privacy*. Press **MENU/SELECT** again to turn privacy mode on (you'll see a **P** in the display). When you hang up, privacy mode turns off automatically.

As long you have privacy mode on, no other handsets can interrupt your call. To allow another handset to join the call, just turn privacy mode off by repeating the process above (press **MENU/SELECT** twice).

## Using Call Transfer

To...	From a handset
transfer a call	<ol style="list-style-type: none"><li>1. Press <b>INTERCOM/CLEAR</b> to put the call on hold.</li><li>2. Select the handset you want to transfer the call to, or select <i>A//</i> to page all the handsets at the same time. When the other handset accepts the call, you'll be disconnected, but you can join the call again.</li></ol>
cancel a transfer	Press <b>TALK /FLASH</b> to return to the call.
accept a transferred call	<ol style="list-style-type: none"><li>1. Press <b>INTERCOM/CLEAR</b> to answer the page and speak to the transferring handset.</li><li>2. To accept the call, press <b>TALK/FLASH</b>.</li></ol>

## Using the Intercom

Here are some things you need to know about using the intercom:

- ◆ Whenever the phone is in standby, you can make an intercom call between handsets without using the phone line.
- ◆ You can make an intercom call from any handset, but only two handsets can be in an intercom call at any time.
- ◆ If an outside call comes in during an intercom call, the phone shows the CID information. If the other handset hasn't answered the page, the phone cancels the page so you can answer the incoming call.

To...	From a handset
make an intercom page	1. Press <b>INTERCOM/CLEAR</b> . 2. Select the handset you want to talk with, or select <i>All</i> to page all the handsets at the same time.
cancel a page	Press <b>END</b> .
answer an intercom page	Press <b>INTERCOM/CLEAR</b> or <b>TALK /FLASH</b> .
leave an intercom call	Press <b>END</b> .
answer an outside call during an intercom call	Press <b>TALK/FLASH</b> .

## Do Not Disturb (DND)

You can silence the ringers on all handsets for a specific period of time.

- 1) With the phone in standby, press and hold **#DND** on any handset. The phone prompts you to select the number of hours (1 - 9 or Always On) that you want it to stay in silent mode.
- 2) To confirm, press **#DND** or just wait about 5 seconds. The phone displays Do Not Disturb on each handset.
- 3) After the selected number of hours, the phone automatically exits DND mode. To exit DND mode manually, press and hold **#DND** again.

## Solving Problems

If you have any trouble with your phone, try these simple steps first. If you still have a question, visit the website listed on the front cover.

If...	Try...
No handsets can make or receive calls.	<ul style="list-style-type: none"><li>- Checking the telephone cord connection.</li><li>- Disconnecting the base AC adapter. Wait a few minutes, then reconnect it.</li></ul>
One handset can't make or receive calls.	<ul style="list-style-type: none"><li>- Moving the handset closer to the base.</li><li>- Resetting the handset.</li></ul>
A handset can make calls, but it won't ring.	<ul style="list-style-type: none"><li>- Making sure the ringer is turned on.</li><li>- Make sure DND mode is turned off (see page 24).</li></ul>
A handset's display won't turn on.	<ul style="list-style-type: none"><li>- Charging the battery for 15-20 hours.</li><li>- Checking the battery pack connection.</li></ul>
A handset is not working.	<ul style="list-style-type: none"><li>- Charging the battery for 15-20 hours.</li><li>- Checking the battery pack connection.</li><li>- Resetting the handset.</li></ul>
A handset says <i>Unavailable</i> .	<ul style="list-style-type: none"><li>- Moving the handset closer to the base.</li><li>- Seeing if another handset has Privacy Mode on.</li><li>- Making sure the base is plugged in.</li></ul>
No handsets will display any Caller ID information.	<ul style="list-style-type: none"><li>- Letting calls ring at least twice before answering.</li><li>- Seeing if the call was placed through a switchboard.</li><li>- Checking with your telephone service provider to make sure your Caller ID service is active.</li></ul>
Caller ID displays briefly & then clears.	<ul style="list-style-type: none"><li>- You may have to change the line mode. Contact customer service for more information.</li></ul>
I can't transfer calls.	<ul style="list-style-type: none"><li>- Resetting all the handsets.</li></ul>
I can't get two handsets to talk to the caller.	<ul style="list-style-type: none"><li>- Making sure both handsets are registered to this base.</li><li>- Making sure no handset is in Privacy Mode.</li></ul>
The phone keeps ringing if I answer on an extension.	<ul style="list-style-type: none"><li>- You may have to change the line mode. Visit the website for more information.</li></ul>
I can't register a handset.	<ul style="list-style-type: none"><li>- Seeing if you already have 12 (XDECT 8005) handsets registered to this base.</li><li>- Resetting the handset.</li></ul>

## Weak or Hard To Hear Audio

If a caller's voice sounds weak or soft, the signal might be blocked by large metal objects or walls; you might also be too far from the base, or the handset's battery may be weak.

- ◆ Try moving around while you're on a call or moving closer to the base to see if the sound gets louder.
- ◆ Make sure the handset's battery is fully charged.
- ◆ Try adjusting the earpiece volume or the audio tone (see below).

## Noise or Static On The Line

Interference is the most common cause of noise or static on a cordless phone. Here are some common sources of interference:

- ◆ electrical appliances, especially microwave ovens
- ◆ computer equipment, especially wireless LAN equipment and DSL modems
- ◆ radio-based wireless devices, such as room monitors, wireless controllers, or wireless headphones or speakers
- ◆ large florescent light fixtures (especially if they give off a buzzing noise)
- ◆ other services that use your phone line, like alarm systems, intercom systems, or broadband Internet service

### **Do you use a T-Coil hearing aid?**

If you have a hearing aid equipped with a telecoil (T-coil) feature, the interaction between the hearing aid & digital cordless phones can cause noise in the handset. If you have a T-coil hearing aid & you have problems with noise on the line, try turning on *T-coil* mode. Open the menu. Select *Handset Setup*, then select *T-coil*.

**Using T-coil mode can shorten the handset's talk time; make sure to watch the battery status and keep the battery charged.**

## Here are some hints for when the static is...

on 1 handset or in 1 location:	on all handsets or in all locations:
<ul style="list-style-type: none"><li>- Check nearby for one of the common interference sources.</li><li>- Try moving the handset away from a suspected source, or try moving the suspected source so it's not between the handset &amp; the base.</li><li>- Try moving closer to the base. There is always more noise at the edges of the base's range. If the handset displays an <i>Out of Range</i> message, you need to move closer to the base.</li></ul>	<ul style="list-style-type: none"><li>- Check near the base for the source of interference.</li><li>- Try moving the base away from a suspected source, or turn off the source if possible.</li><li>- If the base has an adjustable antenna, try raising the antenna so it stands straight up.</li><li>- If you have any service that uses the phone line, you might need a filter (see below).</li></ul>

### Installing a line filter or DSL filter

Sometimes, broadband Internet services that use the telephone line can interfere with phones. One of these services -DSL- often causes static on telephones.

A DSL filter or telephone line filter usually solves this problem. The technician who installed your DSL service might have left some filters for you; if not, call your DSL provider or look in any electronics store. Plug the DSL filter into the telephone wall jack and plug your phone's base into the filter. Make a test call to make sure the noise is gone.

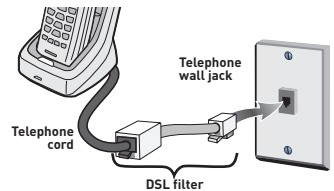

## Resetting and Registering Handsets

If you are having trouble with a handset or if you want to replace one, you need to clear the registration information from the base and the handset:

Do you have the base the handset is registered to?	
Yes	No
<ol style="list-style-type: none"><li>1. Press &amp; hold <b>END</b> and <b>#</b> until the <i>System Reset</i> menu appears (about 5 seconds).</li><li>2. Select <i>Deregister HS</i>. The display lists all registered handsets.</li><li>3. Select the handset you want to reset.</li><li>4. When the phone asks you to confirm, select <i>Yes</i>. The handset clears its information from the base &amp; deletes its own link to the base.</li></ol>	<ol style="list-style-type: none"><li>1. Press &amp; hold <b>END</b> and <b>#</b> until the <i>System Reset</i> menu appears (about 5 seconds).</li><li>2. Select <i>Base Unavailable</i>.</li><li>3. When the phone asks you to confirm, select <i>Yes</i>. The handset deletes its own link without contacting the base.</li></ol>

When you reset a handset (or if you buy a new one), that handset displays a *Handset Not Registered* message. If you see this message on a handset, you need to register it to a base before you can use it.

### Registering a handset

Place the unregistered handset into the main base for charging to start the registration process.

If...	Try...
<ul style="list-style-type: none"><li>- you don't hear a dial tone</li><li>- the display says <i>Registration Failed</i></li></ul>	Making sure the handset is fully charged, then start over.

**To register a handset to a different base, see the section "Expanding Your Phone" in the user's guide for the other base.**

## Handling Liquid Damage

Moisture and liquid can damage your cordless phone.

- ◆ If the handset or base is exposed to moisture or liquid, but only the exterior plastic housing is affected, wipe off the liquid, and use as normal.
- ◆ If moisture or liquid has entered the plastic housing (i.e. liquid can be heard in the phone or liquid has entered the handset battery compartment or vent openings on the base), follow these steps:

Handset	Base
<ol style="list-style-type: none"><li>1. Remove the battery cover &amp; disconnect the battery.</li><li>2. Let dry for at least 3 days with the battery disconnected and the cover off for ventilation.</li><li>3. After the handset dries, reconnect the battery pack and replace the cover. Recharge the battery fully (15-20 hours) before using.</li></ol>	<ol style="list-style-type: none"><li>1. Disconnect the AC adapter to cut off the power.</li><li>2. Disconnect the telephone cord.</li><li>3. Let dry for at least 3 days before reconnecting.</li></ol>

**IMPORTANT: You must unplug the telephone line while recharging the battery pack to avoid charge interruption.**

---

***CAUTION! DO NOT use a microwave oven to speed up the drying process. This will cause permanent damage to the handset, base and the microwave oven.***

---

## Important Information

### Terms Used In This Guide

Accessory handset	An extra handset that can register to and be used with an expandable phone base. All accessory handsets must be registered to a base before you can use them.
Base	The main part of the phone. It connects to your phone line and lets you make and receive calls. Most bases also have a cradle to store a handset.
Call Waiting	A service that lets you receive calls while you are on another call.
Caller ID	(Also called CID.) A service that shows the name and number of incoming callers.
Charger	A cradle that stores and charges a handset but doesn't connect to the phone line.
Cradle	The part of the phone that stores a handset. While in a cradle, a handset is always in standby, and any keys are locked.
During a call	The handset is currently on a call or has activated a dial tone.
Handset	A cordless handset that you use to dial the phone and talk to callers.
In standby	The phone is inactive: there is no dial tone, no handset is on a call or listening to messages.

## Specifications

AC adapter		Base	Charger
	Part number	PS-S0635YL3	AAD-600S(M)
	Input voltage	240V AC, 50 Hz	240V AC, 50Hz
	Output voltage	6V DC @ 350mA	9V DC@ 210mA
Battery pack	Part number	BT-694 or BT-694s	
	Capacity	650mAh (BT-694) or 500mAh(BT-694s)	

- ◆ Use only the supplied AC adapters.
- ◆ Be sure to use the proper adapter for the base & any chargers.
- ◆ Do not place the power cord where it creates a trip hazard or where it could become chafed & create a fire or electrical hazard.
- ◆ Do not place the base in direct sunlight or subject it to high temperatures.

## Automatic ECO (Power Save) Mode

### Handset

ECO mode activates automatically during Talk or Intercom modes, if the received signal is good, to reduce power consumption. **ECO** shows on the display when ECO mode is active. If the received signal becomes poor, ECO mode will be released and **ECO** will be turned off.

### Base

If the base has only one handset registered (i.e. no accessory handsets) then the base will reduce its transmission power when the handset is on the base.

## Battery Information

- ◆ Fully charged, the battery should provide about 10 hours of talk time and about 7 days of standby time. For best results, return the handset to the cradle after each call to keep it fully charged.
- ◆ Keep an eye on the battery status icon. When the battery gets too low, the handset shows a low battery alert. If you hear a strange beep during a call, check the display: if you see the low battery alert, finish your conversation as quickly as possible and return the handset to the cradle. If the handset is in standby, none of the keys will operate.
- ◆ With normal use, the battery should last about one year. Replace the battery when the talk time becomes short even when the battery is charged. To buy a replacement battery, visit the website listed on the front cover.

### *Rechargeable Nickel-Metal-Hydrate Battery Warning*

---

***CAUTION! Risk of explosion if battery is replaced by an incorrect type! Dispose of used batteries according to the instructions. Do not open or mutilate the battery. Disconnect the battery before shipping this product.***

---

- ◆ This equipment contains a rechargeable Nickel-Metal-Hydrate battery.
- ◆ The rechargeable batteries contained in this equipment may explode if disposed of in a fire.
- ◆ Do not short-circuit the battery.
- ◆ Do not charge the rechargeable battery pack used in this equipment with in any charger other than the one designed to charge this battery pack as specified in the owner's manual. Using another charger may damage the battery pack or cause the battery pack to explode.

**Uniden works to reduce lead content in PVC coated cords in our products & accessories.**

# INDEX

- A**  
Any Key Answer ..... 13  
AutoTalk ..... 13
- B**  
Banner ..... 13  
Battery  
    Preparing and charging ..... 6, 7  
    Replacement and handling ..... 31, 32  
Belt Clip ..... 7
- C**  
Caller ID  
    Caller ID service ..... 17  
    Calling ..... 17  
    Call Waiting ..... 18  
    Deleting ..... 18  
    Storing ..... 18  
    Using ..... 17  
    Viewing ..... 17  
Call transfer feature ..... 23  
Chain dialing ..... 20  
Clock (see Date & Time)  
Conference Calling ..... 22
- D**  
Date & Time ..... 14  
Deregister the handset ..... 28  
Distinctive ringer (see Personal Ring)  
Do Not Disturb ..... 10, 24
- E, F, G**  
Earpiece volume ..... 16  
ECO mode ..... 31  
Expanding your phone ..... 22  
Features ..... 5  
Find handset ..... 20
- H**  
Hands-free conversation ..... 16  
Headset installation ..... 8
- I, J, K, L**  
Intercom ..... 10, 24  
Insert Zero ..... 14  
Keypad Lock ..... 10  
Key Touch Tone ..... 13
- LCD contrast ..... 13  
Line Filter ..... 27  
Liquid Damage ..... 29
- M, N, O**  
Making a call ..... 16  
Mute ..... 10, 16  
Noise ..... 26
- P, Q**  
Package contents ..... 3  
Paging handset (see Find handset)  
Personal Ring ..... 13  
Phonebook ..... 19  
    Editing ..... 15, 19  
    Erasing ..... 19  
    Making calls ..... 19  
    Storing ..... 19  
    Viewing ..... 19  
    Chain dialing ..... 20  
Privacy mode ..... 23
- R**  
Receiving a call ..... 16  
Redialing a call ..... 17  
Register the handset ..... 28  
Resetting the handset ..... 28  
Ringer  
    Ringer melodies & tones ..... 13  
    Ringer volume ..... 16
- S**  
Setting up  
    base unit ..... 6, 7, 8  
    extra handset ..... 6, 7  
    handset ..... 6, 7, 8  
Static (see Noise)
- T, U, V,**  
Transferring a call ..... 23  
Troubleshooting ..... 25  
Voice Mail ..... 21  
    Programming ..... 14
- W, X, Y, Z**  
Wall Mounting the Base ..... 8  
Warranty ..... 34

# One Year Limited Warranty

## **UNIDEN XDECT 8015, XDECT 8015+1/+2/+3**

**IMPORTANT** Satisfactory evidence of the original purchase is required for warranty service

Please refer to our Uniden website for any details or warranty durations offered in addition to those contained below.

### **Warrantor**

The warrantor is either Uniden Australia Pty Limited ABN 58 001 865 498 ("Uniden Aust") or Uniden New Zealand Limited ("Uniden NZ") as the case may be.

### **Terms of Warranty**

Uniden Aust/NZ warrants to the original retail purchaser only that the XDECT 8015, XDECT 8015+1/+2/+3 ("the Product"), will be free from defects in materials and craftsmanship for the duration of the warranty period, subject to the limitations and exclusions set out below.

### **Warranty Period**

This warranty to the original retail purchaser is only valid in the original country of purchase for a Product first purchased either in Australia or New Zealand and will expire one (1) year from the date of the original retail sale.

If a warranty claim is made, this warranty will not apply if the Product is found by Uniden to be:

- (A) Damaged or not maintained in a reasonable manner or as recommended in the relevant Uniden Owner's Manual;
- (B) Modified, altered or used as part of any conversion kits, subassemblies or any configurations not sold by Uniden Aust or Uniden NZ;
- (C) Improperly installed contrary to instructions contained in the relevant Owner's Manual
- (D) Repaired by someone other than an authorized Uniden Repair Agent in relation to a defect or malfunction covered by this warranty; or
- (E) Used in conjunction with any equipment, parts or a system not manufactured by Uniden.

### **Parts Covered**

This warranty covers the Product and included accessories.

### **User-generated Data**

This warranty does not cover any claimed loss of or damage to user-generated data (including but without limitation phone numbers, addresses and images) that may be stored on your Product.

### **Statement of Remedy**

If the Product is found not to conform to this warranty as stated above, the Warrantor, at its discretion, will either repair the defect or replace the Product without any charge for parts or service. This warranty does not include any reimbursement or payment of any consequential damages claimed to arise from a Product's failure to comply with the warranty.

Our goods come with guarantees that cannot be excluded under the Australian Consumer Law. You are entitled to a replacement or refund for a major failure and for compensation for any other reasonably foreseeable loss or damage. You are also entitled to have the goods repaired or replaced if the goods fail to be of acceptable quality and the failure does not amount to a major failure.

This warranty is in addition to and sits alongside your rights under either the COMPETITION AND CONSUMER ACT 2010 (Australia) or the CONSUMER GUARANTEES ACT (New Zealand) as the case may be, none of which can be excluded.

### **Procedure for Obtaining Warranty Service**

Depending on the country in which the Product was first purchased, if you believe that your Product does not conform with this warranty, you should deliver the Product, together with satisfactory evidence of your original purchase (such as a legible copy of the sales docket) to Uniden at the addresses shown below. You should contact Uniden regarding any compensation that may be payable for your expenses incurred in making a warranty claim. Prior to delivery, we recommend that you make a backup copy of any phone numbers, images or other data stored on your Product, in case it is lost or damaged during warranty service.

#### **UNIDEN AUSTRALIA PTY LTD**

Service Division  
345 Princes Highway,  
Rockdale, NSW 2216  
Phone number: 1300 366 895  
Email address: [custservice@uniden.com.au](mailto:custservice@uniden.com.au)

#### **UNIDEN NEW ZEALAND LTD**

Service Division  
150 Harris Road, East Tamaki  
Auckland 2013  
Phone number: (09) 273 8377  
Email address: [service@uniden.co.nz](mailto:service@uniden.co.nz)

**Uniden®**

© 2011 Uniden Australia Pty/Uniden New Zealand Limited  
Printed in Vietnam U01UN340BZB(0)